

SCHAEFFLER

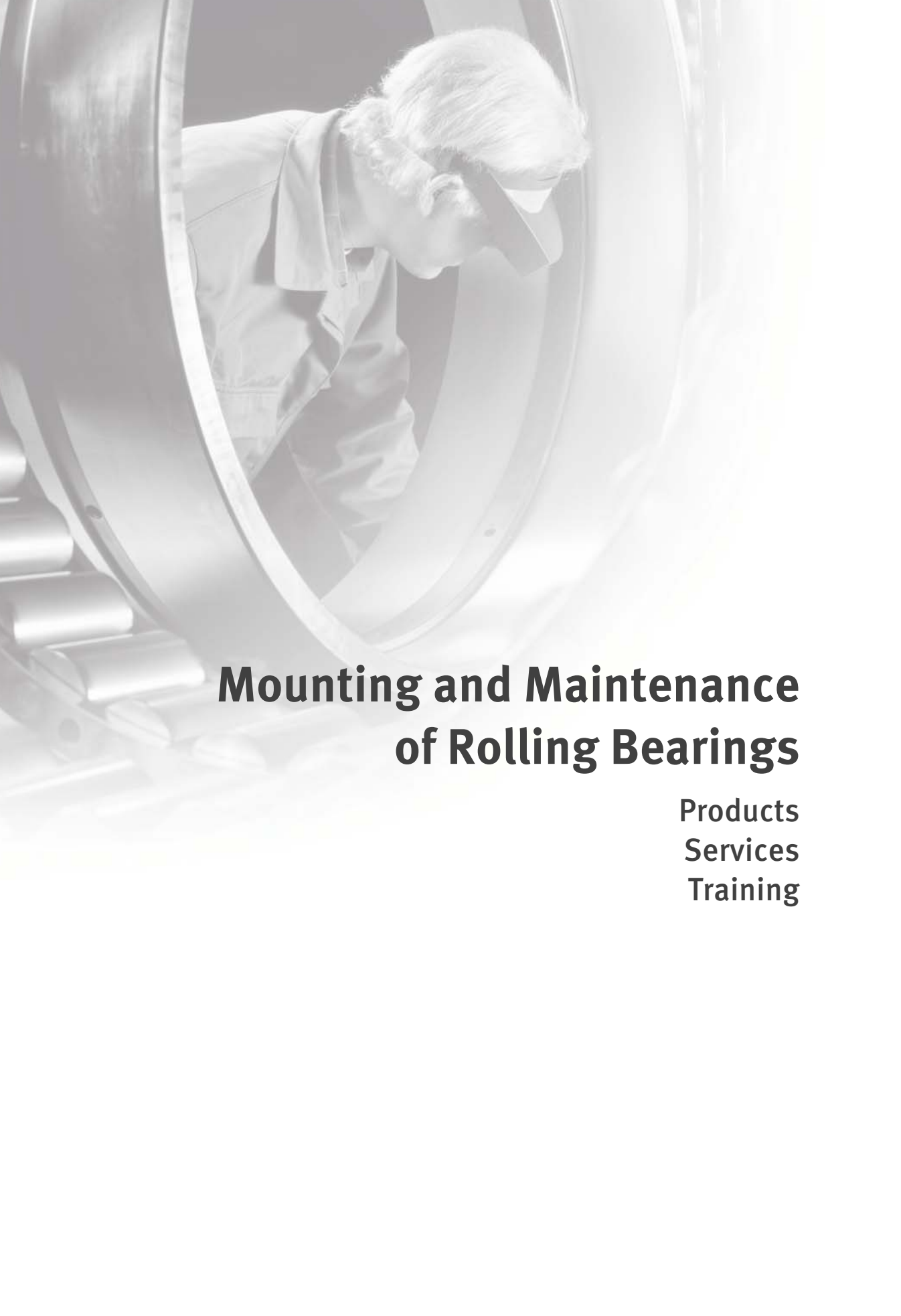

Mounting and Maintenance of Rolling Bearings

Products · Services · Training



Mounting and Maintenance of Rolling Bearings

**Products
Services
Training**

All data have been prepared with a great deal of care and checked for their accuracy. However, no liability can be assumed for any incorrect or incomplete data. We reserve the right to make technical modifications.

© Schaeffler Technologies AG & Co. KG

Issued: 2017, May

Reproduction in whole or in part without our authorisation is prohibited.

Foreword

Industrial Service

This catalogue is aimed principally at maintenance managers and operators of plant in which rolling bearings and other rotating machine components play a critical role in determining the quality of products and processes. Those responsible for maintenance and production processes must be able to rely every day on the quality of their tools and the expertise of their service providers.

Within its Industrial Service concept, Schaeffler therefore offers high quality products, services and training, *Figure 1*.

Portfolio

This catalogue gives an overview of the portfolio:

- Mechanical maintenance
- Lubrication
- Condition monitoring
- Reconditioning.

The employees of Schaeffler worldwide will be pleased to help you select the ideal products, services and training courses, *Figure 1*.



Figure 1
Portfolio

Foreword

Saving on maintenance costs

Schaeffler Industrial Service is responsible for replacement parts and service business for end customers and sales partners in all significant industrial sectors. On the basis of innovative solutions, products and services relating to rolling and plain bearings, Schaeffler offers a comprehensive portfolio that covers all phases in the lifecycle of the rolling bearing and takes account of the total costs (TCO).

The aim is to help customers save on maintenance costs, optimise plant availability and avoid unforeseen machine downtime.

Schaeffler Industrial Service offers an individual and concept solution to each customer irrespective of the manufacturer involved.

Schaeffler has centres of competence all around the world. This means we can provide customers worldwide with products, services and training quickly and professionally. All service employees worldwide undergo a comprehensive training programme and are audited regularly by officially certified specialists. This ensures that services throughout the world conform to a uniformly high standard of quality.

The quality requirements are strongly influenced by a long history of high precision rolling bearing manufacture. The manufacture of the products and the provision of all services in this catalogue is proven in practice and is secured by a quality management system certified in accordance with ISO 9001:2015.

Sales partners

In order to achieve this objective, we have created a network of Schaeffler sales partners. This network makes it possible to support all end customers worldwide with the same high level of expertise. The addresses of all sales partners certified by Schaeffler can be found at www.schaeffler.de/sales.

Mounting Toolbox – mounting made easy

The Schaeffler Mounting Toolbox, *Figure 2*, brings together valuable knowledge relating to the mounting and dismounting of rolling bearings. In individual video sequences, the service experts present step by step the points that must be paid close attention for correct mounting, lubrication and alignment. The interface is a “Virtual Plant” and offers the user easy, rapid navigation. With just a few clicks of the mouse, it is possible to gain an overview of the tools and accessories as well as to select individual video sequences. Internet access is all that is needed to enter the “Virtual Plant” and watch the Schaeffler fitting personnel at work.

Link to Mounting Toolbox:
<http://mtb.schaeffler.de>

Figure 2
Mounting Toolbox



Contents

	Page
Product index	8
Tab index	12
Products: Mounting	15
Products: Lubrication	67
Products: Condition monitoring	89
Services	122
Training courses	142
Appendix	
Publications	
Addresses	

Product index

	Page
ARCA-GREASE-GUN	Lever grease gun..... 77
ARCA-PUMP-BARREL	Drum pump 77
ARCA-PUMP-BARREL.GUN-METER	Pistol grease gun 76
ARCALUB-X.CHAIN-PINION	Chain lubrication pinion..... 76
ARCALUB-X.PINION	Lubrication gear..... 76
ARCANOL-ANTICORROSIONOIL	Anti-corrosion oil 64
ARCANOL-MOUNTINGPASTE	Mounting and multi-purpose paste..... 64
ARCANOL-CLEAN-M	Special grease for clean room applications..... 70
ARCANOL-FOOD2	Special grease for rolling bearings in the food industry..... 70
ARCANOL-LOAD150	Heavy duty grease for all applications with linear contact 70
ARCANOL-LOAD220	Heavy duty grease for rolling mill plant, paper machinery and rail vehicles 70
ARCANOL-LOAD400	Heavy duty grease for main bearings in wind turbines, mining machinery and construction machinery 70
ARCANOL-LOAD460	Heavy duty grease for large rolling bearings..... 70
ARCANOL-LOAD1000	Heavy duty grease for large rolling bearings with very high loads, low speeds and strong vibrations..... 70
ARCANOL-MULTITOP	Multi-purpose grease for demanding applications, wide temperature range 70
ARCANOL-MOTION2	Special greases for rolling bearings and linear systems with oscillating operation..... 70
ARCANOL-MULTI2	Multi-purpose grease for rolling bearings ($D \leq 62$) 70
ARCANOL-MULTI3	Multi-purpose grease for rolling bearings ($D > 62$) 70
ARCANOL-SPEED2,6	Special grease for high speed applications at high speeds and low loads 70
ARCANOL-TEMP90	High temperature grease for applications with continuous limit temperature of up to +90 °C 70
ARCANOL-TEMP110	High temperature grease for applications with continuous limit temperature of up to +110 °C 70
ARCANOL-TEMP120	High temperature grease for applications with continuous limit temperature of up to +120 °C 70
ARCANOL-TEMP200	High temperature grease for applications with continuous limit temperature of up to +200 °C 70
ARCANOL-VIB3	Special grease for applications with strong vibrations or oscillating movements 70

	Page
BEARING-MATE	Transport and mounting tool..... 64
CONCEPT-PRECISION-GREASE	Grease lubrication system for spindle bearings 76
CONCEPT-PRECISION-OIL	Oil lubrication system for spindle bearings..... 76
CONCEPT2	Two-point lubricator with grease cartridge..... 76
CONCEPT8	Multi-point lubrication system with LC unit..... 76
DETECT3-KIT	Vibration measuring device 104
DETECT3-KIT-RFID	Vibration measuring device with automatic measurement point detection..... 104
DETECT3.BALANCE-KIT	Balancing function for vibration measuring device 104
DTECTX1-S	Online monitoring system 104
DTECTX1-S-WIPRO	Online monitoring system 104
FEELER-GAUGE-100	Feeler gauge..... 58
FEELER-GAUGE-300	Feeler gauge..... 58
FITTING-TOOL-ALU-10-50	Mounting tool set 18
GREASE-CHECK	Grease sensor 118
HEATER50	Induction heating device for workpieces up to a mass of 50 kg..... 42
HEATER100	Induction heating device for workpieces up to a mass of 100 kg..... 42
HEATER200	Induction heating device for workpieces up to a mass of 200 kg..... 42
HEATER400	Induction heating device for workpieces up to a mass of 400 kg..... 43
HEATER800	Induction heating device for workpieces up to a mass of 800 kg..... 43
HEATER1600	Induction heating device for workpieces up to a mass of 1600 kg..... 43
HEAT-GENERATOR	Generator for heating device with medium frequency technology 50
HEAT-INDUCTOR	Inductor for heating device with medium frequency technology 50
HYDNUT	Hydraulic nut..... 28
LASER-EQUILIGN	Shaft alignment device 92
LASER-SHIM	Shim 92
LASER-SMARTY2	Belt pulley alignment device..... 92
LASER-TRUMMY2	Belt tension measuring device 92
LOCKNUT-DOUBLEHOOK	Double hook wrench..... 18
LOCKNUT-DOUBLEHOOK-...-SET	Double hook wrench set 18
LOCKNUT-HOOK	Hook wrench 18
LOCKNUT-HOOK-KM0-16-SET	Hook wrench set..... 18
LOCKNUT-SOCKET	Socket wrench..... 18

Product index

	Page
MGA31	Enveloping circle gauge for external enveloping circle..... 58
MGI21	Enveloping circle gauge for internal enveloping circle 58
MGK132	Taper gauge 58
MGK133	Taper gauge 58
PRO-CHECK	Online monitoring system 104
PULLER-HYD	Hydraulic extractor..... 19
PULLER-TRISECTION	Three-section extraction plate 19
PULLER-2ARM	Two-arm extractor 19
PULLER-2ARM-SEPARATOR	Two-arm extractor 19
PULLER-2ARM-SET	Two-arm extractor set..... 19
PULLER-3ARM	Three-arm extractor..... 19
PUMP1000-0,7L	Single stage hand pump 28
PUMP1000-4L	Twin stage hand pump 28
PUMP1000-8L	Twin stage hand pump 28
PUMP1000.MANO-DIGI	Digital manometer 29
PUMP1000.MANO-G1/2	Manometer 29
PUMP1600-4L	Twin stage hand pump 28
PUMP1600-8L	Twin stage hand pump 28
PUMP1600.MANO-G1/2	Manometer 29
PUMP1600.VALVE-NIPPLE	Nipple for rapid push fit couplings 29
PUMP1600.VALVE-SOCKET	Socket for rapid push fit couplings 29
PUMP2500-4L	Twin stage hand pump 28
PUMP2500-8L	Twin stage hand pump 28
PUMP.ADAPTER	Adapter 29
PUMP.NIPPLE	Adapter and reduction nipple..... 29
PUMP.SLEEVE-CONNECTOR	Sleeve connector 29

	Page
SMART-CHECK Online monitoring system	104
SMART-QB Online monitoring system	104
SNAP-GAUGE Snap gauge	58
TOOL-RAILWAY-AGGREGATE Mobile hydraulic unit for batch mounting of TAROL bearings....	28
TOOL-RAILWAY-AXLE Tool set for mobile hydraulic unit	28
TOOL-RAILWAY-CLEARANCE-BASIC Axial clearance gauge for mounting of TAROL bearings	59
TOOL-RAILWAY-CLEARANCE.TOP Adapter set for axial clearance gauge	59
TOOL-RAILWAY-INSPECTION-DEVICE Visual inspection device for preparation of TAROL bearings	59
TOOL-RAILWAY-GREASER Greasing tool for TAROL bearings	77
TOOL-RAILWAY-SEALCAP Sealing cap tool for hydraulic press	29
TOOL-RAILWAY-SEALCAP-PRESS Hydraulic press for dismounting and mounting of seals on TAROL bearings.....	29
WEAR-DEBRIS-CHECK Particle sensor	118





0009F980

Products: Mounting



0008A942

Products: Lubrication



00019DD6

Products: Condition Monitoring



000A326C

Services



000A32D8

Training courses



0001A281

Appendix

- Publications
- Addresses



Products: Mounting

Products: Mounting

	Page
Mechanical mounting and dismounting	Product overview 18
	Features
	Mounting tool sets 20
	Socket wrenches 21
	Hook and double hook wrenches 22
	Mechanical extractors 24
	Hydraulic extractors 26
Three-section extraction plates 27	
Hydraulic mounting and dismounting	Product overview 28
	Features
	Software Mounting Manager 30
	Hydraulic nuts 31
	Pressure generation devices 33
	Mobile hydraulic unit 35
	Hydraulic press 37
Connectors, accessories 38	
Thermal mounting, induction heating devices	Product overview 42
	Features
	Induction heating devices HEATER 44
	Accessories 46
	FAG Heating Manager 47
Dimension tables	
Heating devices HEATER, product range 48	
Thermal mounting and dismounting, medium frequency technology	Product overview 50
	Features
Induction units with medium frequency technology 51	

	Page
Measurement and inspection	
Product overview	58
Features	
Feeler gauges.....	60
Taper gauges	60
Snap gauges.....	61
Enveloping circle gauges.....	62
Visual inspection device	63
Axial clearance gauge	63
Accessories	
Product overview	64
Features	
Transport and mounting tool	65
Mounting paste.....	66
Anti-corrosion oil	66



Product overview Mechanical mounting and dismounting

Mounting tool sets Socket wrenches

FITTING-TOOL-ALU-10-50



LOCKNUT-SOCKET



Hook and double hook wrenches Hook wrenches

LOCKNUT-HOOK



LOCKNUT-HOOK-KM0-16-SET

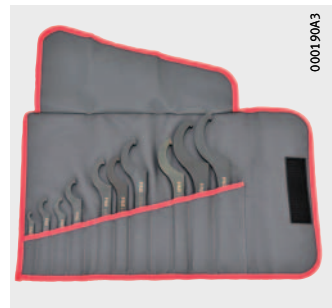

Double hook wrenches

LOCKNUT-DOUBLEHOOK



Double hook wrench set

LOCKNUT-DOUBLEHOOK-...-SET



Mechanical extractors

Two-arm extractors
Two-arm extractor set

PULLER-2ARM,
PULLER-2ARM-SEPARATOR



PULLER-2ARM-SET



Three-arm extractors

PULLER-3ARM

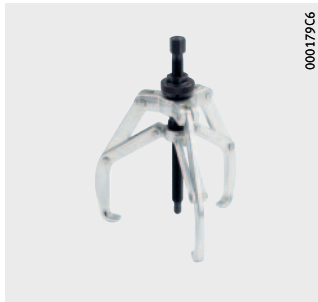

Hydraulic extractors

PULLER-HYD



Three-section
extraction plates

PULLER-TRISECTION



Mechanical mounting and dismounting

Features These mechanical tools are designed for the mounting and dismounting of bearings. The mounting forces are transmitted by the form fit effect.

Mounting tool sets The mounting tool sets are suitable for the simple mounting of rolling bearings with a bore of up to 50 mm, *Figure 1*. They can also be used for the mounting of sleeves, intermediate rings, seals and similar parts.

A mounting tool set contains mounting sleeves made from aluminium and mounting rings made from plastic.



Figure 1
Mounting tool set

An error frequently made during mounting is to transmit the mounting forces through the rolling elements and raceways. This error can be avoided by driving the inner ring onto the shaft or driving the outer ring into the housing by applying hammer blows to an appropriate mounting sleeve. The precision parts are matched to each other, ensuring that the forces are uniformly transmitted to the end faces of the bearing rings.

Scope of delivery Mounting tool set comprising 33 mounting rings for bearing bore 10 mm to 50 mm and outside diameter up to 110 mm
3 mounting sleeves
1 recoilless hammer, mass 1 kg
1 case

Ordering designation **FITTING-TOOL-ALU-10-50**
Also available as individual parts.

Further information

- TPI 216, Tools for the Mechanical Mounting and Dismounting of Rolling Bearings
- Enquiries:
industrial-services@schaeffler.com, +49 2407 9149-66.

Socket wrenches

Socket wrenches LOCKNUT-SOCKET are suitable for the simple tightening and loosening of locknuts on shafts, adapter sleeves and withdrawal sleeves. They require less space on the circumference of the nut than hook wrenches and allow the use of ratchets and torque wrenches, *Figure 2*.



Figure 2

Socket wrench and torque wrench

For increased reliability, socket wrenches should be secured using a locking pin and rubber ring. They therefore have a hole for the locking pin and a groove for the rubber ring. The locking pin and rubber ring are included in the scope of delivery.

Socket wrenches are available in sizes suitable for locknuts KM0 to KM20. Other sizes and special solutions are available by agreement.

Scope of delivery	1 socket wrench 1 locking pin 1 rubber ring
Ordering example	Socket wrench, suitable for locknut KM5
Ordering designation	LOCKNUT-SOCKET-KM5 Special sizes available by agreement.
Further information	■ TPI 216, Tools for the Mechanical Mounting and Dismounting of Rolling Bearings ■ Enquiries: industrial-services@schaeffler.com, +49 2407 9149-66.

Mechanical mounting and dismounting

Hook and double hook wrenches

These wrenches are used to move locknuts or extraction nuts for the mounting or dismounting of rolling bearings or withdrawal sleeves.

Hook wrenches

A hook wrench LOCKNUT-HOOK can be used to dismount not only bearings but also withdrawal sleeves with the aid of extraction nuts. Hook wrenches are available in sizes suitable for locknuts KM0 to KM40, suitable for diameters from 16 mm to 245 mm.

Ordering example
Ordering designation

Hook wrench, suitable for locknuts KM18, KM19 and KM20
LOCKNUT-HOOK-KM18-20

These wrenches can be used for the mounting and dismounting of small bearings on shaft seats, adapter sleeves or withdrawal sleeves. In addition to the sizes stated here, other sizes are available by agreement.

Ordering example
Ordering designation

Set comprising ten hook wrenches
LOCKNUT-HOOK-KM0-16-SET

Hook wrenches can also be ordered as a set. The set comprises ten hook wrenches of sizes KM0 to KM16 in a roll-up pouch and is suitable for diameters from 16 mm to 100 mm.

Double hook wrenches

Double hook wrenches LOCKNUT-DOUBLEHOOK are intended for the mounting of spherical roller bearings and self-aligning ball bearings with a tapered bore, *Figure 3*. The individual wrenches are available as a set.



Figure 3
Double hook wrenches



The double hook wrench sets contain a torque wrench. This allows a precisely defined tightening torque to be achieved at the start of the mounting operation.

Double hook wrench sets are suitable for several sizes of locknuts. There is one set each for locknuts KM3 to KM8 and for locknuts KM9 to KM15. All the parts in the scope of delivery are also available individually.

Each double hook wrench is engraved with the torsion angles for the appropriate spherical roller bearings and self-aligning ball bearings. The drive-up distance and reduction in radial internal clearance can thus be precisely set.

Scope of delivery	Several double hook wrenches 1 torque wrench 1 mounting lever 1 user manual 1 case 1 mounting paste (20 g)
Ordering example	4 double hook wrenches, suitable for locknuts KM3 to KM8
Ordering designation	LOCKNUT-DOUBLEHOOK-KM3-8-SET
Ordering example	5 double hook wrenches, suitable for locknuts KM9 to KM15
Ordering designation	LOCKNUT-DOUBLEHOOK-KM9-15-SET

Mechanical mounting and dismounting

Mechanical extractors

Mechanical extractors can be used to dismount small and medium sized rolling bearings that are located with a tight fit on a shaft or in a housing. The bearing can be dismounted without damage if the extractor is in contact with the tightly fitted bearing ring.

In the case of mechanical extractors, the extraction force is normally applied by means of threaded spindles.

In addition to the two-arm and three-arm devices as well as a hydraulic pressure tool, special solutions are also possible.

For the dismounting of larger bearings, hydraulic extractors should be used, see page 26.

Two-arm and three-arm extractors

Two-arm and three-arm extractors, *Figure 4*, *Figure 5* and tables, page 25, are used for the extraction of complete rolling bearings or tightly fitted inner rings.

The two-arm extractor PULLER-2ARM and three-arm extractor PULLER-3ARM can also be used to extract other parts such as gears.

Figure 4
Two-arm extractor,
dimensions of gripper

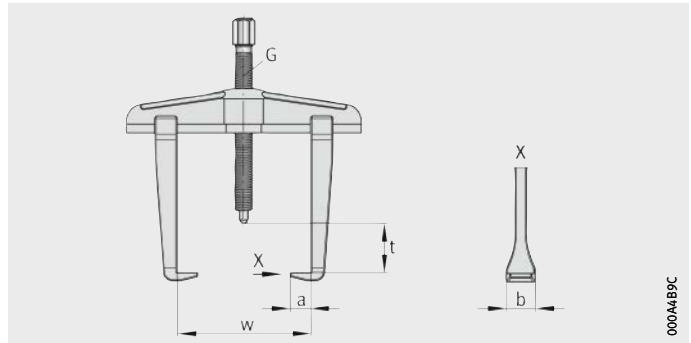
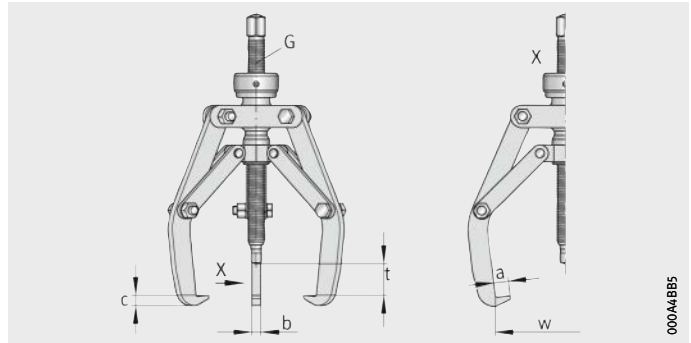

Figure 5
Three-arm extractor,
dimensions of gripper



Available two-arm extractors

Designation	Grip span w mm	Grip depth t mm	Dimensions		Extraction force kN
			a mm	b mm	
PULLER-2ARM90	90	100	15	22	30
PULLER-2ARM130	130	100	15	22	30
PULLER-2ARM160	160	150	24	30	50
PULLER-2ARM200	200	150	24	30	50
PULLER-2ARM250	250	200	32	36	75
PULLER-2ARM350	350	200	32	36	75
PULLER-2ARM-SEPARATOR45	45	65	2,5	12 ⁺¹	10
PULLER-2ARM-SEPARATOR90	90	100	2,5	14 ⁺¹	40
PULLER-2ARM-SEPARATOR150	150	150	2,5	28 ⁺¹	40



Available two-arm extractor set

Designation: PULLER-2ARM-SET
Two-arm extractors included PULLER-2ARM130, PULLER-2ARM200, PULLER-2ARM350
Accessories included Narrow extraction hook for size 130 and 200, tube of spindle grease, carry case

Available three-arm extractors

Designation	Grip span w mm	Grip depth t mm	Dimensions		Extraction force kN
			a mm	b mm	
PULLER-3ARM160	160	100	14 ⁺¹	15 ⁺¹	45
PULLER-3ARM230	230	165	19 ⁺¹	22 ⁺¹	100
PULLER-3ARM310	310	235	19 ⁺¹	22 ⁺¹	100
PULLER-3ARM430	430	240	20 ⁺²	30 ⁺²	150
PULLER-3ARM660	660	340	22 ⁺²	34 ⁺²	150

Further information

- TPI 216, Tools for the Mechanical Mounting and Dismounting of Rolling Bearings
- Enquiries: industrial-services@schaeffler.com, +49 2407 9149-66.

Mechanical mounting and dismantling

Hydraulic extractors

Hydraulic extractors, see tables, are used where higher extraction forces are required.

These devices allow rolling bearings, gears, sleeves and many other shrink fitted parts to be quickly and easily dismantled.

For larger grip depths, the XL design or longer extraction arms are available as accessories.

Operating personnel can be protected by means of a safety grid or a safety cover.

The advantageous features of hydraulic extractors are as follows:

- parts under mechanical load made from high quality chromium-molybdenum steel
- smooth-running, chromium plated piston made from hardened and tempered steel
- stroke travel adjustable by means of standard adapter
- screw thread for setting of optimum grip depth
- simple centring by spring-loaded steel cone
- simple conversion to two-arm operation in case of insufficient space for three arms
- optimum operating position due to rotatable pump hand lever or separate pump.

Available hydraulic extractors with integral hand pump

Designation	Extraction force kN	Grip span		Grip depth		Stroke length mm
		Standard mm	XL mm	Standard mm	XL mm	
PULLER-HYD40	40	200	–	165	–	55
PULLER-HYD60(-XL)	60	200	260	165	210	82
PULLER-HYD80(-XL)	80	260	300	210	240	82
PULLER-HYD100(-XL)	100	250	280	185	210	82
PULLER-HYD120(-XL)	120	300	330	240	280	82
PULLER-HYD200(-XL)	200	360	380	275	330	82
PULLER-HYD250(-XL)	250	410	440	315	380	110
PULLER-HYD300(-XL)	300	540	540	405	610	110

Available hydraulic extractors with separate hand pump

Designation	Extraction force kN	Grip span		Grip depth		Stroke length mm
		Standard mm	XL mm	Standard mm	XL mm	
PULLER-HYD400(-XL)	400	580	1 000	420	635	125

Further information

- TPI 216, Tools for the Mechanical Mounting and Dismounting of Rolling Bearings
- Enquiries:
industrial-services@schaeffler.com, +49 2407 9149-66.

Three-section extraction plates

Three-section extraction plates PULLER-TRISECTION, see table, can be used with hydraulic and mechanical extractors.

These allow the extraction of complete bearings, tightly fitted inner rings and other components.

The load carrying capacity is matched to the maximum extraction force of the hydraulic extractors used in each case. In order to prevent damage to the bearing during extraction, the geometrical form of the three extraction segments means that they grip the bearing on the inner ring only.

The extraction plates can be fitted under the bearing with just a few movements.

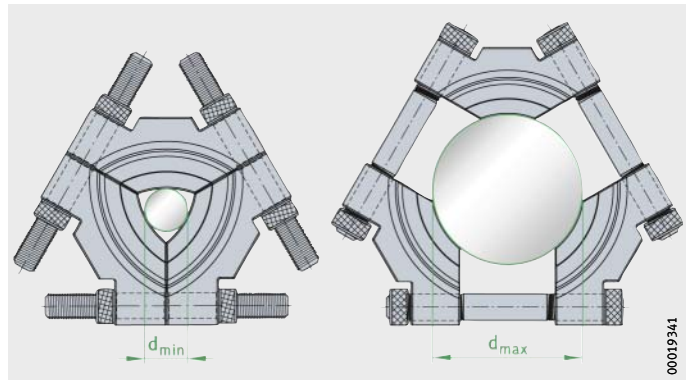

Figure 6
Maximum and minimum diameter
of extraction plates, see table

Available three-section extraction plates

Designation	Dimensions		Recommended for extractor	
	$d_{\min}^{1)}$ mm	$d_{\max}^{1)}$ mm	PULLER-HYD	PULLER-3ARM
PULLER-TRISECTION-50	12	50	–	160
PULLER-TRISECTION-100	26	100	40, 60, 80, 100	230
PULLER-TRISECTION-160	50	160	80, 100, 120, 175, 200	310
PULLER-TRISECTION-260	90	260	175, 200, 250, 300	430
PULLER-TRISECTION-380	140	380	250, 300, 400	660

¹⁾ d_{\min} and d_{\max} , Figure 6.

Further information

- TPI 216, Tools for the Mechanical Mounting and Dismounting of Rolling Bearings
- Enquiries:
industrial-services@schaeffler.com, +49 2407 9149-66.

Product overview Hydraulic mounting and dismounting

Hydraulic nuts

HYDNUT



Hand pumps Single stage

PUMP1000-0,7L



Twin stage

PUMP1000-4L, PUMP1000-8L, PUMP1600-4L, PUMP1600-8L, PUMP2500-4L, PUMP2500-8L



Mobile hydraulic unit Tool set

TOOL-RAILWAY-AGGREGATE



TOOL-RAILWAY-AXLE



Hydraulic press
Sealing cap tool

**TOOL-RAILWAY-SEALCAP-
PRESS**



000A37B8

TOOL-RAILWAY-SEALCAP



000A37BD



Connectors, accessories
Adapters and reduction nipples
Rapid push fit coupling

**PUMP.NIPPLE,
PUMP.ADAPTER**



000179C3

**PUMP1600.VALVE-NIPPLE,
PUMP1600.VALVE-SOCKET**



00019DDB

Digital manometer
Manometer

PUMP1000.MANO-DIGI



000179BD

**PUMP1000.MANO-G1/2,
PUMP1600.MANO-G1/2**



000179B5

Sleeve connector

PUMP.SLEEVE-CONNECTOR



00017AC7

Hydraulic mounting and dismounting

Features	Hydraulic tools can be used to apply large forces. These tools are therefore particularly suitable for the mounting and dismounting of large bearings or parts with a tapered bore. Hydraulic nuts are used as a mounting tool. Pressure can be generated using hand pumps.
Software Mounting Manager	<p>The program Mounting Manager gives assistance in selecting the correct mounting of bearings and offers the following options:</p> <ul style="list-style-type: none">■ It shows various mechanical and hydraulic mounting methods.■ It calculates the data required for mounting in relation to reduction in radial internal clearance, drive-up distance and start pressure.■ It gives advice on mounting.■ It generates a list of the accessories and tools required. <p>It also contains a library with references to publications giving further information and an electronic learning system. The program Mounting Manager is available online at http://mountingmanager.schaeffler.com/startApp.do</p>
Mounting method	Bearings with a tapered bore are mounted either directly on the tapered shaft or journal or by means of an adapter sleeve or withdrawal sleeve on the cylindrical shaft. The internal clearance is set either by measurement of the axial drive-up distance or by conventional means using feeler gauges.
Measurement of the axial drive-up distance	For measurement of the drive-up distance, a dial gauge is screwed into the hydraulic nut. The dial gauge is preloaded and the measurement sensor then precisely follows the displacement of the press ring. This value corresponds to the displacement of the rolling bearing on the tapered seat.
Measurement of the reduction in radial internal clearance	When the bearing is driven onto the tapered seat, the inner ring is expanded and the radial internal clearance is thereby reduced. This reduction in radial internal clearance is an indication of the tight fit of the bearing. Measurement is carried out using a feeler gauge.

Hydraulic nuts

Hydraulic nuts HYDNUT, *Figure 1* and table, are used to press components with a tapered bore onto their tapered seat. Presses are mainly used if the drive-up forces required cannot be applied using other accessories, e.g. shaft nuts or pressure screws.



Figure 1
Hydraulic nut with dial gauge

The main applications are as follows:

- Rolling bearings with a tapered bore can be mounted and dismantled.
Bearings can be seated directly on a tapered shaft, an adapter sleeve or a withdrawal sleeve. The hydraulic nut can also be used for the dismantling of adapter or withdrawal sleeves.
- Components such as couplings, gears and ships' propellers can be mounted and dismantled.

Available hydraulic nuts

Designation	Design	Application
HYDNUT50..-E to HYDNUT200..-E	With metric fine pitch thread to DIN 13	Standardised adapter and withdrawal sleeves
HYDNUT205..-E to HYDNUT1180..-E	With trapezoidal thread to DIN 103	With metric dimensions
HYDNUT90-E-INCH to HYDNUT530-E-INCH	With inch size thread to ABMA "Standards for Mounting Accessories, Section 8, Locknut Series N-00"	Sleeves with inch dimensions
HYDNUT100-HEAVY to HYDNUT900-HEAVY	Increased capacity design with smooth bore	For high mounting forces, for example in shipbuilding

Hydraulic mounting and dismantling

Scope of delivery

The scope of delivery comprises the hydraulic nut, accessories and user manual, *Figure 2*.

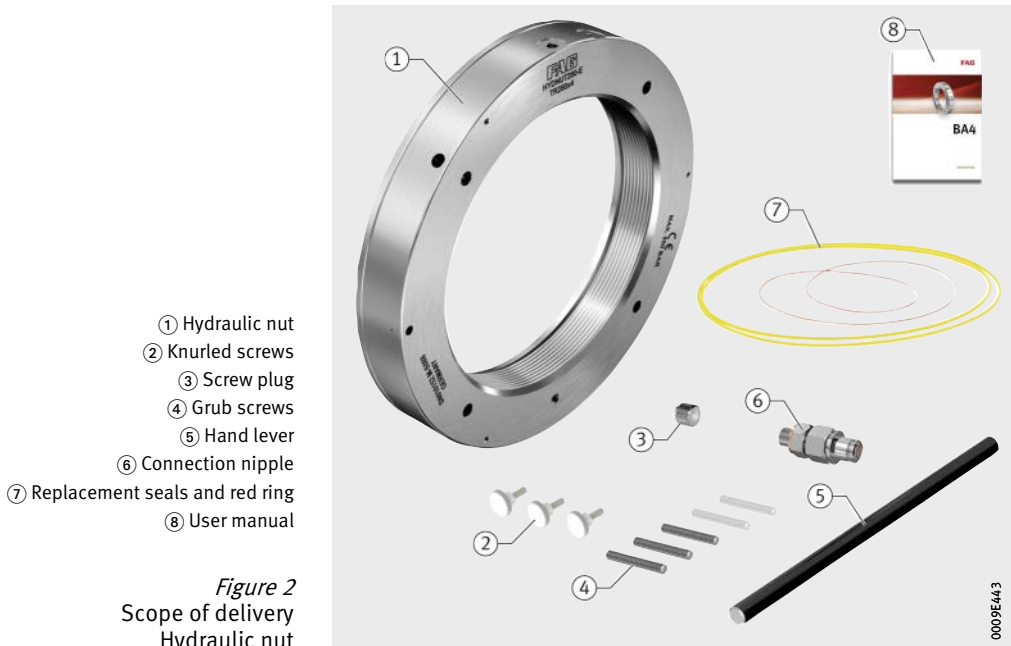

Figure 2
Scope of delivery
Hydraulic nut

Scope of delivery

- 1 hydraulic nut
- 2 replacement seals
- 1 red ring
- 1 screw plug
- 3/5 grub screws
- 1 connection nipple
- 3 knurled screws
- 1 hand lever
- 1 user manual

Ordering designation

HYDNUT

Further information

- TPI 196, FAG Hydraulic Nuts
- Enquiries:
industrial-services@schaeffler.com, +49 2407 9149-66.

Pressure generation devices

Pressure generation devices are available in various designs: from the hand pump via the mobile hydraulic unit to the hydraulic press, see tables.



Application Hand pump

Designation	Application
PUMP1000-0,7L	<ul style="list-style-type: none"> ■ Mounting and dismounting of rolling bearings ■ For driving hydraulic nuts up to HYDNUT395 or HYDNUT300-HEAVY
PUMP1000-4L	<ul style="list-style-type: none"> ■ Mounting and dismounting of rolling bearings ■ Mounting and dismounting of components such as ships' propellers ■ For driving hydraulic nuts up to HYDNUT800
PUMP1600-4L	<ul style="list-style-type: none"> ■ Mounting and dismounting of rolling bearings ■ Mounting and dismounting of components such as rudder splines and rudder blades
PUMP2500-4L	<ul style="list-style-type: none"> ■ Mounting and dismounting of bearings ■ Mounting and dismounting of components such as gears and couplings

Application Mobile hydraulic unit

Designation	Application
TOOL-RAILWAY-AGGREGATE	<ul style="list-style-type: none"> ■ Mounting and dismounting of tapered roller bearing units (TAROL)

Application Hydraulic press

Designation	Application
TOOL-RAILWAY-SEALCAP-PRESS	<ul style="list-style-type: none"> ■ Mounting and dismounting of seals on tapered roller bearing units (TAROL)

Further information

- TPI 195, FAG Pressure Generation Devices.

Hydraulic mounting and dismantling

Hand pumps Hand pumps have a single stage or twin stage pump with a manometer.

Single stage pump The hand pump PUMP1000-0,7L has an oil container with a volume of 0,7 l. The maximum oil pressure is 1 000 bar, see table. A digital manometer is available as an accessory.

Available single stage pump

Designation	Maximum oil pressure bar
PUMP1000-0,7L	1 000

Twin stage pump The twin stage pumps, *Figure 3* and table, have a high delivery rate up to 50 bar and then switch automatically to the high pressure stage. This gives a high work rate.



Figure 3
Twin stage pump,
4-l oil container

Where there is an increased oil requirement, the twin stage pumps are available with an 8-l oil container (suffix 8L). If the type of mounting of the adapter or withdrawal sleeve requires a separate oil supply, a two-way valve is available (suffix D).

For pumps with an oil pressure of 1 000 bar and a connector, digital manometers are also available as accessories.

Available twin stage pumps

Designation	Maximum oil pressure bar
PUMP1000-4L	1 000
PUMP1600-4L	1 600
PUMP2500-4L	2 500

Mobile hydraulic unit

The mobile hydraulic unit, *Figure 4*, is used for the mounting and dismounting of tapered roller bearing units, also known as TAROL units. These units are used as wheelset bearings in rail vehicles such as goods wagons and passenger carriages.

The mobile unit has a valve-controlled, double direction pressure cylinder driven by a motor pump. The pressure cylinder is adjustable in height.

When making enquiries or placing orders, information on the power connection is required.



Figure 4
Mobile hydraulic unit

Ordering designation

TOOL-RAILWAY-AGGREGATE

00017A51

Hydraulic mounting and dismounting

Tool set Tool sets are produced for a specific application, *Figure 5*. When making enquiries or placing orders, information on the bearing type and installation drawings (shaft, housing, additional parts) are required.



Figure 5
Tool set

Ordering designation **TOOL-RAILWAY-AXLE**

Hydraulic press

The hydraulic press, *Figure 6*, is used for the mounting and dismounting of seals on tapered roller bearing units, also known as TAROL units. In addition, a matching tool set is required for each bearing type.



Figure 6
Hydraulic press

Ordering designation

TOOL-RAILWAY-SEALCAP-PRESS

Sealing cap tool

Sealing cap tools are bearing-specific and include all the parts for mounting and dismounting of the seal. For dismounting, the parts required are an adapter ring, a punch and the appropriate press-out segments. For mounting of the new seal, a support and the appropriate press-in ring are supplied.

Ordering designation

TOOL-RAILWAY-SEALCAP

Further information

- TPI 195, FAG Pressure Generation Devices
- TPI 156, Tapered Roller Bearing Units TAROL – Mounting, Maintenance, Repair
- Enquiries:
industrial-services@schaeffler.com, +49 2407 9149-66.

Hydraulic mounting and dismounting

Connectors, accessories

Various connectors and accessories are available for use with the devices for hydraulic mounting and dismounting.

Adapters and reduction nipples

Adapters and reduction nipples are matched to the threads of high pressure hoses and pipes, *Figure 7* and tables.

Adapters and reduction nipples of type A (with sealing ring) are suitable for oil pressures up to 800 bar, *Figure 7*. Type B (with blade sealing) is suitable for oil pressures up to 2 500 bar, *Figure 7*.

- ① Type A
- ② Type B

Figure 7

Adapters and reduction nipples

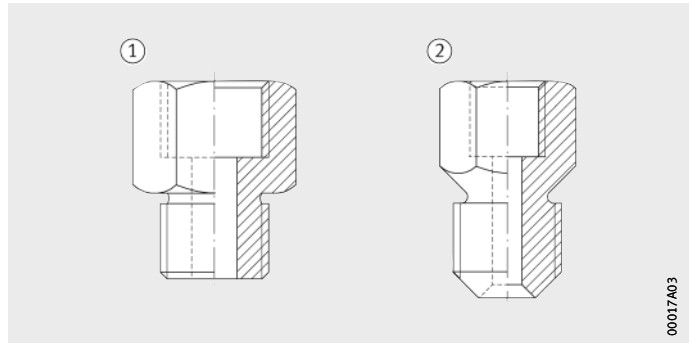

Available adapters and reduction nipples

Designation	Designation
PUMP.NIPPLE-A-G1/4-G1/8	PUMP.NIPPLE-A-G3/4-G1/8
PUMP.NIPPLE-B-G1/4-G1/8	PUMP.NIPPLE-B-G3/4-G1/8
PUMP.NIPPLE-A-G1/4-G1/2	PUMP.NIPPLE-A-G3/4-G1/4
PUMP.NIPPLE-B-G1/4-G1/2	PUMP.NIPPLE-B-G3/4-G1/4
PUMP.NIPPLE-A-G1/4-G3/4	PUMP.NIPPLE-A-G3/4-G3/8
PUMP.NIPPLE-B-G1/4-G3/4	PUMP.NIPPLE-B-G3/4-G3/8
PUMP.NIPPLE-A-G1/4-M14	PUMP.NIPPLE-A-M18×1,5-G1/4
PUMP.NIPPLE-B-G1/4-M14	PUMP.NIPPLE-A-M18×1,5-G3/8
PUMP.NIPPLE-A-G1/4-M18×1,5	PUMP.NIPPLE-A-M18×1,5-G3/8
PUMP.NIPPLE-A-G3/8-G1/4	–
PUMP.NIPPLE-B-G3/8-G1/4	–

Available adapters

Designation	Designation
PUMP.ADAPTER-A-G1/4	PUMP.ADAPTER-A-G3/4
PUMP.ADAPTER-B-G1/4	PUMP.ADAPTER-B-G3/4

Rapid push fit coupling

A suitable connecting nipple is always included in the delivery of a hydraulic nut. Each hand pump with an oil pressure up to 1600 bar is supplied with a rapid push fit coupling. The rapid push fit coupling allows rapid connection and disconnection of a hose and is suitable for oil pressures up to 1600 bar, *Figure 8* and table.



After the coupling has been fitted, the high pressure hose must be secured to the connection point by means of a chain or cord.

- ① Nipple
- ② Socket



Figure 8
Rapid push fit coupling

Available nipple and socket

Designation	Threaded connector inch	Component
PUMP1600.VALVE-NIPPLE	G ¹ / ₄	Nipple
PUMP1600.VALVE-SOCKET	G ¹ / ₄	Socket

Hydraulic mounting and dismounting

Manometer

In addition to the manometer with digital display, there are three analogue manometers with an indicator, see table.



When selecting a manometer, pay attention to the maximum oil pressure.

Available manometers

Designation	Threaded connector inch	Maximum oil pressure bar
PUMP1000.MANO-DIGI	G ¹ / ₄	1 000
PUMP1000.MANO-G1/2	G ¹ / ₂	1 000
PUMP1600.MANO-G1/2	G ¹ / ₂	1 600

Sleeve connectors

Sleeve connectors can be used at pressures up to 800 bar.

The connector to the pump holder is G¹/₄. The connector to the consumer device is available in the sizes M6, M8, G¹/₈ and G¹/₄. For other thread sizes, a reduction nipple can be used.



Check the oil pressure using a manometer.

Ordering example
Ordering designation

Sleeve connector with a connector G¹/₈ on the consumer device side
PUMP.SLEEVE-CONNECTOR-G1/8



Product overview Thermal mounting, induction heating devices

Tabletop devices

HEATER50



HEATER100



HEATER200



Standalone devices

HEATER400



0009DF60



HEATER800



0009DF66

HEATER1600



0009DF5C

Thermal mounting, induction heating devices

Features

Induction heating devices HEATER with mains frequency technology are used to heat rolling bearings and other components with a cylindrical bore where a tight fit on the shaft or in the housing is intended.

Adequate expansion of the bearings is achieved in most cases at +80 °C to +100 °C. During the heating operation, the maximum heating temperature must be observed. The temperature of rolling bearings must not normally exceed +120 °C, in order to prevent changes to the structure and hardness of the bearing. In all devices for heating, the temperature can be steplessly controlled.



Wear protective gloves during mounting and dismantling of heated parts.

Induction heating devices HEATER

The induction heating devices HEATER for rolling bearings up to a mass of 1 600 kg have been improved further in terms of their performance capability and safety compared with their predecessors. They can also be used to heat sealed and greased rolling bearings. In addition to the tabletop devices HEATER50 to HEATER200, the range also includes the standalone devices HEATER400 to HEATER1600 for larger rolling bearings.

The scope of delivery of the induction heating devices HEATER covers a basic setup, *Figure 1*.

- ① Heating device
- ② Slewing ledge
- ③ Temperature sensor
- ④ Lifting tool
- ⑤ User manual

Figure 1
Scope of delivery
Heating device HEATER200



The rolling bearing to be heated is either suspended from the ledge or is laid horizontally on the sliding table, *Figure 2*.



- ① Slewing ledge
- ② U-shaped core
- ③ Rolling bearing
- ④ Sliding table



Figure 2
Heating of rolling bearing

Advantages of FAG heating devices

The advantages of the induction heating devices are:

- very safe operation
- high reliability (TÜV certified)
- effective, energy-efficient heating (high efficiency level)
- uniform, controlled heating
- automatic demagnetisation
- simple operation
- high cost-effectiveness through selection of the device size most suitable for the particular application.

Operating modes

The induction heating devices can be operated in the following modes:

- temperature control
- time control
- ramp control
- delta-T control.

Thermal mounting, induction heating devices

Accessories

The functional scope of an induction heating device can be extended by the use of accessories.

Temperature sensor

Two temperature sensors can be connected to each induction heating device. The sensor head of the temperature sensor is magnetic and is positioned on the component. The signal is fed via the cable and plug to the device, *Figure 3*.

The induction heating devices HEATER50 and HEATER100 are supplied with one temperature sensor. If two temperature sensors are used, it is possible to operate the heating method with delta-T control.

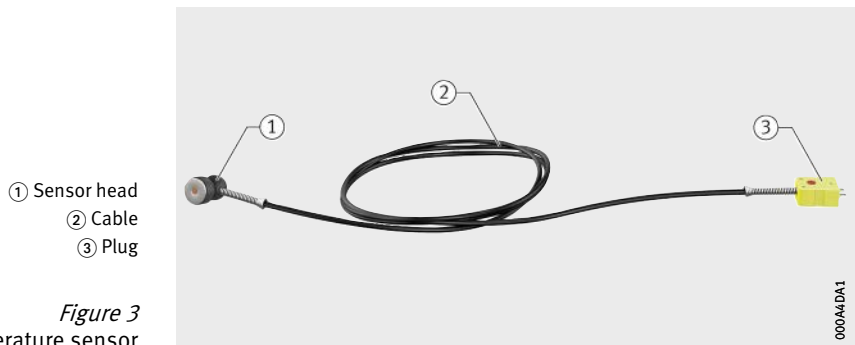

Ledge

Each induction heating device is supplied with one ledge. This ledge has the same cross-section as the U-shaped core and allows maximum power to be achieved.

In order to heat rolling bearings of a smaller inside diameter, ledges with smaller cross-sections are available.

Adapter posts

For the tabletop devices HEATER50, HEATER100 and HEATER200, adapter posts are available. These are always placed in pairs on the U-shaped core and thus increase the inner height. With the aid of adapter posts, it is also possible to heat workpieces with a small inside diameter and a large outside diameter.

Further information

- TPI 200, FAG Heating Devices for the Mounting of Rolling Bearings
- Enquiries:
industrial-services@schaeffler.com, +49 2407 9149-66.

FAG Heating Manager

The software FAG Heating Manager is a user-friendly tool for selection of the optimum heating device for the heating of rolling bearings.

Once the rolling bearing to be heated has been selected, the bearing type, dimensions, mass and the suitable heating device are displayed, *Figure 4*.

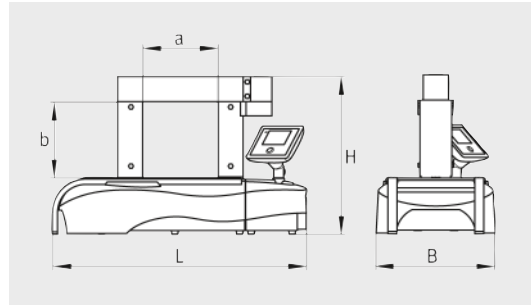

Figure 4
FAG Heating Manager

The FAG Heating Manager is available online at www.schaeffler.de, menu item Mediathek.

Heating devices HEATER

Product range



Dimension table

Characteristics		Unit	HEATER50
			
Operating voltage	U	VAC	110 to 230
Frequency	F	Hz	50 to 60
Power consumption	P	kVA	3
Current rating	I	A	13
Residual magnetism	H	A/cm	< 2
Operating duration	ED	%	100
Mass	m	kg	18
Length	L	mm	450
Width	B	mm	210
Height	H	mm	250
Dimension	a	mm	120
Dimension	b	mm	140
Maximum rolling bearing mass	m	kg	50
Maximum mass of other component	m	kg	40
Maximum width	b	mm	120
Minimum inside diameter ¹⁾	d	mm	55
Minimum inside diameter with accessories	d	mm	10
Maximum inside diameter (lying flat)	d	mm	300
Maximum outside diameter	D	mm	400 (with LEDGE-55)

¹⁾ When using the ledge included in the scope of delivery.

HEATER100	HEATER200	HEATER400	HEATER800	HEATER1600
				
110 to 230	400 to 480	400 to 480	400 to 480	400 to 480
50 to 60	50 to 60	50 to 60	50 to 60	50 to 60
3,7	8	12,8	25,2	40
16	20	32	63	100
< 2	< 2	< 2	< 2	< 2
100	100	100	100	100
35	86	157	280	650
540	695	850	1 080	1 500
275	330	420	500	800
310	370	950	1 250	1 600
180	210	300	430	690
180	210	330	490	700
100	200	400	800	1 600
80	150	300	600	1 200
180	210	330	400	650
70	100	120	150	220
15	20	35	50	90
400	500	900	1 400	1 900
500 (with LEDGE-70)	600 (with LEDGE-100)	1 000 (with LEDGE-120)	1 500 (with LEDGE-150)	2 000 (with LEDGE-220)

Product overview Thermal mounting and dismounting, medium frequency technology

Medium frequency technology

HEAT-INDUCTOR, HEAT-GENERATOR



HEAT-INDUCTOR

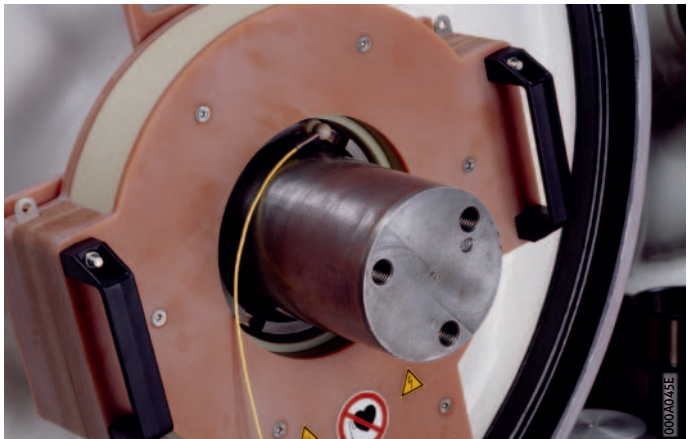

Thermal mounting and dismounting, medium frequency technology



Features Induction units based on medium frequency technology are, in contrast to induction heating devices, suitable not only for thermal mounting but also for dismounting. Furthermore, they can be used for the heating of very large and heavy components.

Adequate expansion of the bearings is achieved in most cases at +80 °C to +100 °C. During the heating operation, the maximum heating temperature must be observed. The temperature of rolling bearings must not normally exceed +120 °C, in order to prevent changes to the structure and hardness of the bearing. In all devices for heating, the temperature can be steplessly controlled.



Wear protective gloves during mounting and dismounting of heated parts.

Induction units with medium frequency technology

Due to their high flexibility and compact construction, these units can also be used for mobile operation. They can therefore be used, for example, at construction sites for wind turbines or for other large components that are difficult to transport.

Application

Examples of the use of medium frequency technology include:

- heating of medium-sized to large bearings for mounting and dismounting
- heating of housings prior to mounting of a bearing
- batch dismounting of bearing inner rings of cylindrical roller bearings and labyrinth rings, for example in the case of wheelset bearings in rail vehicles
- dismounting of bearing inner rings from traction motors in rail vehicles
- heating of large components, for example bearings or machine supports in wind turbines
- heating of roll rings and couplings, for example in steelworks
- loosening of shrink fit connections of gears.

Thermal mounting and dismounting, medium frequency technology

The units comprise a generator and an inductor that is positioned on the workpiece. Depending on the requirements, a rigid or flexible inductor is used. Depending on the application, flexible inductors are positioned in the bore or on the outside diameter of the workpiece, *Figure 1*. Flexible inductors are suitable for the heating of bearing inner rings or of large components such as machine supports in wind turbines. The length of the inductor is defined as a function of the dimensions of the workpiece.



Figure 1
The flexible inductor can be wrapped around the component

Flexible inductors

The flexible inductors are available in two designs that differ mainly in their geometrical characteristics but also in their maximum operating duration, see table.

Technical data on flexible inductors

Designation		Inductor HEAT-INDUCTOR	
		-.M-D15	-.M
Cooling system	–	Air cooling	
Length	m	12 – 16	12 – 40
Diameter	mm	approx. 18	approx. 20
Minimum bending radius	mm	80	150
Mass without plug	kg/m	approx. 0,6	approx. 1
Permissible temperature of work-piece surface	°C	+180	
Maximum temperature at push fit connector	°C	+90	
Maximum operating duration	–	≤ 10 min	∞
Connection of inductor and generator	–	Push fit connector	

The flexible inductors are available in various lengths, see table.

Ordering designations and lengths

Ordering designation	Length m
HEAT-INDUCTOR-12M-D15	12
HEAT-INDUCTOR-14M-D15	14
HEAT-INDUCTOR-16M-D15	16
HEAT-INDUCTOR-12M	12
HEAT-INDUCTOR-16M	16
HEAT-INDUCTOR-20M	20
HEAT-INDUCTOR-24M	24
HEAT-INDUCTOR-27M	27
HEAT-INDUCTOR-30M	30
HEAT-INDUCTOR-40M	40



Rigid inductors

Rigid inductors are particularly suitable for batch production, *Figure 2*. In such cases, the emphasis is less on flexibility and more on short set-up times and high process reliability.

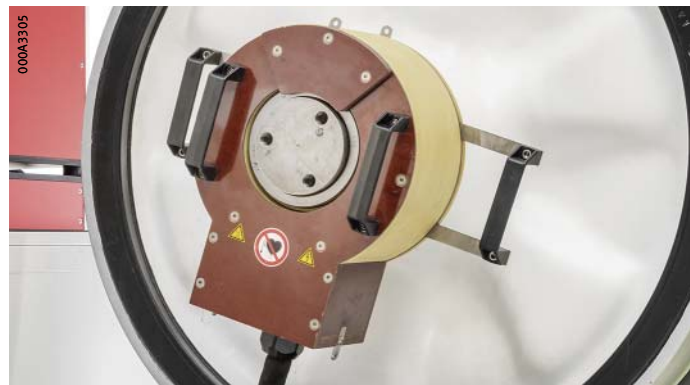

Figure 2
Rigid inductor for dismounting
of wheelset bearings

Thermal mounting and dismounting, medium frequency technology

Generators Compared with preceding models, the generators are of a significantly more compact and lighter design and are thus even more suitable for mobile operation. They are available in two performance variants and two voltage versions, *Figure 3* and tables, page 55.



Figure 3
Generators

Technical data of generators with voltage rating of 400 V

Designation	Generator HEAT-GENERATOR	
	20-2	40-2
Cooling	–	Open circuit ventilation
Mains voltage	V	3×380 – 3×440
Mains frequency	Hz	50 – 60
Voltage tolerance	–	±10%
Connector plug CEE	A	32 63
Line-side fuse protection	A	32 63
Effective power	kW	20 ¹⁾ 40 ¹⁾
Output frequency	kHz	10 – 25
Length of mains connection cable	m	5
Width	mm	277 365
Depth (with mains connection cable)	mm	610
Height (with grips)	mm	540 695
Mass	kg	30 55

1) Valid for voltage rating of 400 V.

**Technical data of generators
with voltage rating of 480 V**

Designation	Generator HEAT-GENERATOR	
	20-2-480V	40-2-480V
Cooling	–	Open circuit ventilation
Mains voltage	V	3×460 – 3×500
Mains frequency	Hz	50 – 60
Voltage tolerance	–	±10%
Connector plug CEE	A	32 63
Line-side fuse protection	A	32 63
Effective power	kW	20 ¹⁾ 40 ¹⁾
Output frequency	kHz	10 – 25
Length of mains connection cable	m	5
Width	mm	277 365
Depth (with mains connection cable)	mm	610
Height (with grips)	mm	540 695
Mass	kg	30 55



¹⁾ Valid for voltage rating of 480 V.

Digital control

Digital control is carried out by means of a 7" TFT display and has the following characteristics:

- presentation of temperature patterns on the display
- storage and export of temperature patterns by means of an integrated temperature recorder
- separate registration for operator and service operator, with different access rights
- alarm functions for protection of the workpiece against overheating
 - temperature increase alert
 - temperature alarm on overshoot
- user languages: German and English
- remote access possible via an Ethernet interface.

Thermal mounting and dismounting, medium frequency technology

- Advantages** The advantages of the heating device with medium frequency technology are as follows:
- suitable for mounting
 - suitable for dismounting
 - operating frequency from 10 kHz to 25 kHz
 - efficiency of the generator higher than 90%
 - low energy requirements
 - short heating times
 - time and temperature control as well as other operating modes
 - automatic demagnetisation
 - flexible and rigid inductors available
 - inductors suitable for use either inside or outside the component
 - lower mains connection power than heating devices with mains frequency
 - almost silent
 - air-cooled system.

Configuration Each of the light and compact devices is designed for the specific application. It can be equipped, depending on the workpiece, with flexible or rigid inductors.

For enquiries, the following data are required:

- bearing dimensions, if possible with drawings
- representation of the adjacent construction
- data on the fit conditions
- description of the mounting process and its frequency
- power supply data
- ambient conditions
- your address.

- Further information**
- TPI 217, Induction Units with Medium Frequency Technology
 - Enquiries:
industrial-services@schaeffler.com, +49 2407 9149-66.



Product overview Measurement and inspection

Feeler gauges

FEELER-GAUGE-100,
FEELER-GAUGE-300



000179A9

Taper gauges

MGK133

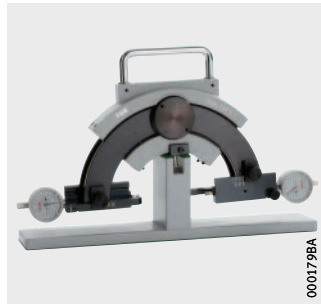

000179BA

MGK132

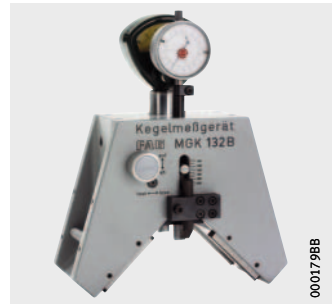

000179BB

Snap gauges

SNAP-GAUGE



000179A7

Enveloping circle gauges

MGI21



000179A5

MGA31



000179A6

Visual inspection device

**TOOL-RAILWAY-INSPECTION-
DEVICE**



Axial clearance gauge
Adapter set

**TOOL-RAILWAY-CLEARANCE-
BASIC**



**TOOL-RAILWAY-CLEARANCE.
TOP**



Measurement and inspection

Features Feeler gauges and measurement gauges can be used to check the production of bearing seats and the mounting of bearings.

Feeler gauges Feeler gauges FEELER GAUGE, see table, are used to measure the radial internal clearance, especially in mounting on tapered shaft seats and on adapter and withdrawal sleeves.

Available feeler gauges

Designation	Feeler length mm	Feeler thickness		
		mm		
FEELER-GAUGE-100	100	0,03	0,08	0,14
		0,04	0,09	0,16
		0,05	0,1	0,18
		0,06	0,12	0,2
		0,07	–	–
FEELER-GAUGE-300	300	0,03	0,12	0,2
		0,04	0,13	0,25
		0,05	0,14	0,3
		0,06	0,15	0,35
		0,07	0,16	0,4
		0,08	0,17	0,45
		0,09	0,18	0,5
		0,1	0,19	–

Taper gauges These gauges are used to inspect tapered bearing seats in production facilities. This is necessary to ensure a good match between the fit surfaces of the bearing and bearing seat. Gauges are available for different taper angles.

Taper gauge for taper 1:12 and 1:30

The taper gauge MGK133 is used for the measurement of external tapers 1:12 and 1:30 with a taper diameter of 27 mm to 205 mm.

The reproducibility of the measurement results is less than 1 µm.

The gauge rests on the workpiece with four hardened and polished pins. The position of the gauge on the taper is defined by these pins and a stop. The stop can be attached to either the front or back of the gauge.

The gauge has two movable measuring brackets. One of these is in contact with the small taper diameter, the other with the large taper diameter. There is a fixed spacing between the measuring brackets. The deviation of the taper diameter from the nominal value is displayed in both measurement planes by a precision indicator.

The gauge is set using a reference taper (available by agreement).

Ordering designation

Available by agreement



**Taper gauge
for taper angle 0° to 6°**

The taper gauge MGK132 is used for the measurement of external tapers with a taper angle of 0° to 6° and a taper diameter of 90 mm to 360 mm.

The reproducibility of the measurement results is less than 1 µm.

The gauge rests on the workpiece with four hardened, ground and lapped ledges. The ledges form an angle of 90°. The position of the gauge on the taper is defined by a stop on the front or back of the gauge.

The measurement slide runs between the support ledges. A dial gauge in the housing acts against the measurement slide and displays the deviation of the taper diameter from the nominal value. The deviation of the taper from the nominal value is displayed by a precision indicator on the measurement slide.

The gauge is set using a reference taper (available by agreement).

Ordering designation

Available by agreement

Snap gauges

Snap gauges SNAP GAUGE, see table, can be used to check the diameter of cylindrical workpieces directly on the machine tool. The snap gauge is also used to set the enveloping circle gauge MGI21.

The snap gauge functions as a comparator gauge. It is set using shims. The deviation from the set value can then be determined.

Available snap gauges

Designation	Diameter range	
	min. mm	max. mm
SNAP-GAUGE-30/60	30	60
SNAP-GAUGE-60/100	60	100
SNAP-GAUGE-100/150	100	150
SNAP-GAUGE-150/200	150	200
SNAP-GAUGE-200/250	200	250
SNAP-GAUGE-250/300	250	300

Shims for numerous diameters are available as accessories.

Ordering example
Ordering designation

Snap gauge for shaft diameter 120 mm
SNAP-GAUGE-100/150

Ordering example
Ordering designation

Shim for shaft diameter 120 mm
SNAP-GAUGE.MASTER120

Measurement and inspection

Enveloping circle gauges

Enveloping circle gauges, see table, can be used to set the radial internal clearance or preload of cylindrical roller bearings.

Available enveloping circle gauges

Designation	Design	For bearings	
		from	to
MGI21	For cylindrical roller bearings with separable inner ring	NNU4920-K	NNU4948-K
		NNU4920	NNU4948
MGA31	For cylindrical roller bearings with separable outer ring	NN3006-K	NNU3048-K
		N1006-K	N1048-K

Bearings with separable inner rings

The enveloping circle gauge MGI21 is used to measure, by means of two hardened and precision ground surfaces, the internal enveloping circle of a roller and cage assembly. One measurement surface is movable.

Before measurement, the gauge is set to the internal enveloping circle of the roller and cage assembly. This setting operation requires a snap gauge such as SNAP GAUGE.

After mounting of the outer ring together with the roller and cage assembly, the enveloping circle diameter is then determined using the gauge MGI in a comparative measurement.

In the case of a bearing with a tapered bore, the enveloping circle measurement is used to calculate its position on the tapered seat of the shaft. During mounting, the bearing is driven to this position. This results in the internal clearance or the preload.

In the case of bearings with a cylindrical bore, preground inner rings (suffix F12) are used and are finish ground to the required bearing diameter.

Ordering example
Ordering designation

Enveloping circle gauge for cylindrical roller bearings NNU4920
MGI21-NNU4920

Bearings with separable outer rings

The enveloping circle gauge MGA31 is used to measure, by means of two hardened and precision ground surfaces, the external enveloping circle of the roller and cage assembly.

The gauge is set to the raceway diameter of the mounted outer ring. This dimension is determined using a conventional internal gauge.

The tapered shaft with the premounted inner ring and roller and cage assembly is then inserted in the gauge. The shaft is driven axially by the hydraulic method until the required radial internal clearance or preload is achieved.

Ordering example
Ordering designation

Enveloping circle gauge for cylindrical roller bearings NN3006-K
MGA31-NN3006

Visual inspection device

In the reconditioning of wheelset bearings for rail vehicles (TAROL units), the bearing inner rings are subjected to visual examination after dismounting and cleaning. In order to check the condition of components, a device with a light and magnifying lens is used to visually assess the raceways, rings and all rolling elements.



Axial clearance gauge

The bearing is mounted on the gauge by means of the adapter set. The dial gauge is positioned on the end face of the outer ring and set to zero. By means of an eccentric mechanism, the bearing is raised by its inner ring and the axial clearance present can be read from the dial gauge.

Base device

The base device is suitable for all TAROL units. It comprises a frame and the measuring unit with a dial gauge.

Ordering example

Axial clearance gauge for TAROL units

Ordering designation

TOOL-RAILWAY-CLEARANCE-BASIC

Bearing-specific adapter set

The adapter set facilitates the precise positioning of the bearing on the base device.

Ordering example

Adapter set for TAROL unit F-578116.TAROL100/175-R-TVP

Ordering designation

TOOL-RAILWAY-CLEARANCE.TOP-100/175

Product overview Accessories

Transport and mounting tool

BEARING-MATE

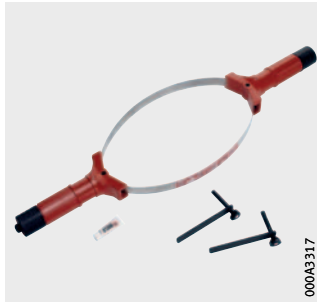

Mounting paste

ARCANOL-MOUNTINGPASTE



Anti-corrosion oil

ARCANOL-ANTICORROSIONOIL



Accessories

Features Accessories are used to assist in the storage, transport and mounting of rolling bearings.



Transport and mounting tool

The transport and mounting tool BEARING MATE, see table, is an accessory for the easy handling of medium-sized and large rolling bearings. It can also be used in the heating of bearings prior to mounting.

The tool comprises two handles and two steel strips. The steel strips are tightly clamped on the outer ring of the bearing. During the transport of spherical roller bearings and self-aligning ball bearings, tilting of the inner rings is prevented by the brackets supplied.

The bearing together with the tool is carried by either two people or by means of a crane. While it is being transported by crane, the bearing is suspended by the tool using the carrying slings and can be rotated into any position required.

During heating by means of an induction heating device HEATER, the bearing can remain in the tool. It expands to the same extent as the bearing. During heating by means of an induction device with medium frequency technology, the flexible inductor must not be in direct contact with the BEARING MATE.

The tool can be used for bearings up to a mass of 500 kg and at temperatures of up to +160 °C.

Available tools

Designation	Bearing outside diameter mm		Mass of tool kg
	from	to	
BEARING-MATE250-450	250	450	6,3
BEARING-MATE450-650	450	650	6,4
BEARING-MATE650-850	650	850	6,5

Ordering example Transport and mounting tool for bearings with an outside diameter from 250 mm to 450 mm with two short brackets

Ordering designation **BEARING-MATE250-450**

Accessories

Accessories, brackets 2 long brackets to prevent tilting of the inner rings of spherical roller bearings

Ordering designation **BEARING-MATE-LOCKBAR270**

Accessories, pack of small parts Pack of small parts

Ordering designation **BEARING-MATE.SERVICE-KIT**

Mounting paste

The mounting paste, see table, facilitates the sliding into place of bearing rings and prevents stick/slip effects, scoring, wear and fretting corrosion. It also gives protection against corrosion.

The operating temperature range is between $-30\text{ }^{\circ}\text{C}$ and $+150\text{ }^{\circ}\text{C}$.

The paste is resistant to water, water vapour and many alkaline and acidic media.

Available mounting pastes

Designation	Container
ARCANOL-MOUNTINGPASTE-70G	Tube containing 70 g
ARCANOL-MOUNTINGPASTE-250G	Tube containing 250 g
ARCANOL-MOUNTINGPASTE-400G	Cartridge containing 400 g
ARCANOL-MOUNTINGPASTE-1KG	Can containing 1 kg

Anti-corrosion oil

This oil gives protection of bearings that have been unpacked. It also gives long term protection against corrosion of bright metallic surfaces, for example on devices and machinery, during storage indoors.

In general, it is not necessary to wash the anti-corrosion oil out of rolling bearings. It gives neutral behaviour towards conventional rolling bearing greases and oils.

The oil can be removed using alkaline solvents or neutral cleaning agents.

Ordering example Spray can containing 0,4 l

Ordering designation **ARCANOL-ANTICORROSIONOIL-400G**



Products: Lubrication

Products: Lubrication

	Page
Lubricants	
Matrix	
Multi-purpose greases	70
Greases for high loads	70
Greases for wide temperature ranges	70
Special greases	70
Features	
Rolling bearing greases Arcanol.....	72
Lubrication devices	
Product overview	76
Features	
Automatic relubrication devices	78
Pistol grease gun	85
Grease pumps.....	86



Grease	Characteristic applications	Operating temperature		Continuous limit temperature °C	Thickener
		°C			
		from	to		
Multi-purpose greases	MULTITOP <ul style="list-style-type: none"> Ball and roller bearings in rolling mills Construction machinery Spinning and grinding spindles Automotive engineering 	-50 ¹⁾	+140	+80	Lithium soap
	MULTI2 <ul style="list-style-type: none"> Ball bearings up to an outside diameter of 62 mm in large electric motors Agricultural and construction machinery Household appliances 	-30	+120	+75	Lithium soap
	MULTI3 <ul style="list-style-type: none"> Ball bearings with an outside diameter of or more than 62 mm in large electric motors Agricultural and construction machinery Fans 	-30	+120	+75	Lithium soap
High loads	LOAD150 <ul style="list-style-type: none"> Ball, roller and needle roller bearings Linear guidance systems in machine tools 	-20	+140	+95	Lithium complex soap
	LOAD220 <ul style="list-style-type: none"> Ball and roller bearings in rolling mill plant Paper machinery Rail vehicles 	-20	+140	+80	Lithium/calcium soap
	LOAD400 <ul style="list-style-type: none"> Ball and roller bearings in mining machinery Construction machinery Wind turbine main bearings 	-40	+130	+80	Lithium/calcium soap
	LOAD460 <ul style="list-style-type: none"> Ball and roller bearings Wind turbines Bearings with pin cage 	-40 ¹⁾	+130	+80	Lithium/calcium soap
	LOAD1000 <ul style="list-style-type: none"> Ball and roller bearings in mining machinery Construction machinery Cement plant 	-30 ¹⁾	+130	+80	Lithium/calcium soap
High temperatures	TEMP90 <ul style="list-style-type: none"> Ball and roller bearings in couplings Electric motors Automotive engineering 	-40	+160	+90	Polycarbamide
	TEMP110 <ul style="list-style-type: none"> Ball and roller bearings in electric motors Automotive engineering 	-35	+160	+110	Lithium complex soap
	TEMP120 <ul style="list-style-type: none"> Ball and roller bearings in continuous casting plant Paper machinery 	-30	+180	+120	Polycarbamide
	TEMP200 <ul style="list-style-type: none"> Ball and roller bearings in guide rollers for baking machinery Kiln trucks and chemical plant Piston pins in compressors 	-30	+260	+200	PTFE
Special requirements	SPEED2,6 <ul style="list-style-type: none"> Ball bearings in machine tools Spindle bearings Rotary table bearings Instrument bearings 	-40	+120	+80	Lithium complex soap
	VIB3 <ul style="list-style-type: none"> Ball and roller bearings in rotors for wind turbines (blade adjustment) Packaging machinery Rail vehicles 	-30	+150	+90	Lithium complex soap
	FOOD2 <ul style="list-style-type: none"> Ball and roller bearings in applications with food contact (NSF-H1 registration, kosher and halal certification) 	-30	+120	+70	Aluminium complex soap
	CLEAN-M <ul style="list-style-type: none"> Ball, roller and needle roller bearings as well as linear guidance systems in clean room applications 	-30	+180	+90	Polycarbamide
	MOTION2 <ul style="list-style-type: none"> Ball and roller bearings in oscillating operation Slewing rings in wind turbines 	-40	+130	+75	Lithium soap

+++ Extremely suitable ++ Highly suitable + Suitable - Less suitable -- Not suitable

1) Measurement values according to Schaeffler FE8 low temperature test.

Base oil	Consistency NLGI	Base oil viscosity at +40 °C mm ² /s	Temperatures		Low friction, high speed	High load, low speed	Vibrations	Support for seals	Relubri- cation facility
			Low	High					
Partially synthetic oil	2	82	+++	++	++	+++	++	+	+++
Mineral oil	2	110	++	+	+	+	+	+	+++
Mineral oil	3	80	++	+	+	+	++	++	++
Mineral oil	2	160	+	++	-	+++	++	++	++
Mineral oil	2	245	+	+	-	+++	++	++	++
Mineral oil	2	400	+	+	-	+++	++	++	++
Mineral oil	1	400	++	+	-	+++	++	-	++
Mineral oil	2	1 000	+	+	--	+++	++	++	++
Partially synthetic oil	3	148	+++	++	+	+	+	++	++
Partially synthetic oil	2	130	+++	+++	++	+	+	+	+
Synthetic oil	2	400	++	+++	-	+++	+	++	+
Alkoxyfluoro oil	2	550	++	+++	--	++	+	+	+
Synthetic oil	2 – 3	25	+++	+	+++	--	-	+	+
Mineral oil	3	170	++	++	-	++	+++	++	-
Synthetic oil	2	150	++	-	+	+	+	+	+++
Ether oil	2	103	+++	+++	+	+	+	+	++
Synthetic oil	2	50	+++	+	-	++	+++	++	+



Lubricants

Features

A significant factor for the performance capability and life of a rolling bearing or linear unit is the selection of a suitable lubricant.

Rolling bearing greases Arcanol

Schaeffler has been investigating for decades which grease is the most suitable solution for which application. The Arcanol rolling bearing greases offer very good preconditions for favourable running behaviour of bearings and a long operating life and high operational security of the bearing arrangement. The lubricant range is graduated such that almost all areas of application are covered.

The areas of application of Arcanol greases were determined under widely differing operating conditions and with rolling bearings of all types by means of modern testing methods and testing systems.

In 2015 alone, Schaeffler used its own FE8 and FE9 test rigs to carry out more than 50 000 hours of testing, *Figure 1* and *Figure 2*, page 73. Arcanol rolling bearing greases have superior characteristics in all areas compared to normal greases.

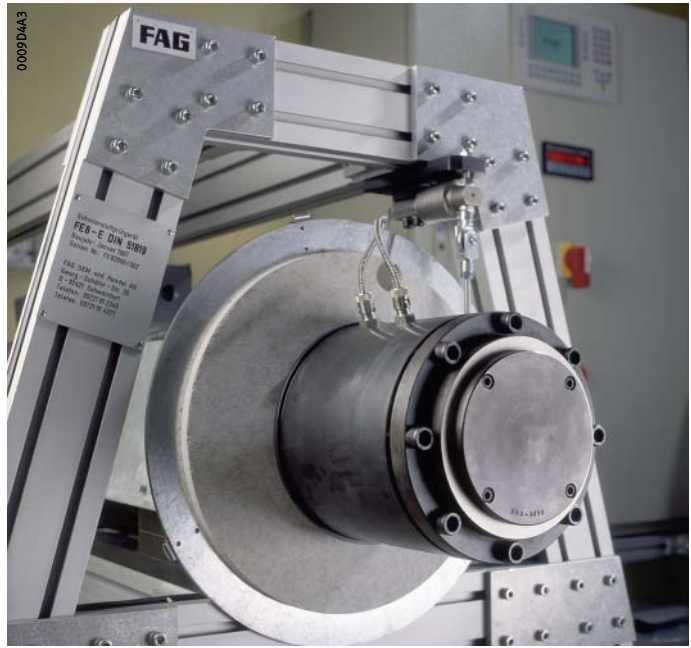

Figure 1
Test rig FE8

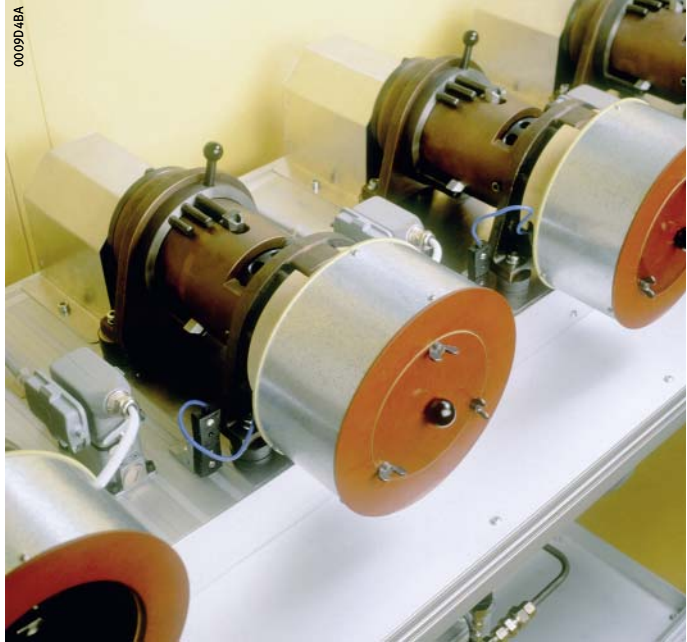

Figure 2
Test rig FE9

Based on the findings of the test rig runs, a range of greases has been developed that is subdivided into four groups:

- Multi-purpose greases:
greases with a wide range of applications
- Heavy duty greases:
greases suitable for high demands on load carrying capacity
- High temperature greases:
greases that must withstand high application temperatures
- Special greases:
greases that have been specially selected for a particular area of application.

**Consistent product quality
as a result of
comprehensive quality inspection**

Each delivery of Arcanol greases is subjected to comprehensive quality inspection. The quality of each batch can be clearly demonstrated and identified. In the in-house analysis laboratory, the chemical and physical characteristics of Arcanol greases are tested in accordance with strict test guidelines, thus ensuring the highest level of product quality.

Lubricants

Grease container sizes

Arcanol grease ¹⁾	Tube		Cartridge 400 g	Can 1 kg
	70 g	250 g		
MULTITOP	–	●	●	●
MULTI2	–	●	●	●
MULTI3	–	●	●	●
LOAD150	–	–	●	●
LOAD220	–	–	●	●
LOAD400	–	–	●	●
LOAD460	–	–	●	●
LOAD1000	–	–	–	–
TEMP90	–	–	●	●
TEMP110	–	–	●	●
TEMP120	–	–	●	●
TEMP200	●	–	–	●
SPEED2,6	–	●	●	●
VIB3	–	–	●	●
FOOD2	–	–	●	●
CLEAN-M	–	●	●	●
MOTION2	–	●	●	●
MOUNTINGPASTE	●	●	●	●

¹⁾ Other containers are available by agreement.

Grease container sizes (continued)

Arcanol grease ¹⁾	Bucket		Hobbock		Drum 180 kg
	5 kg	12,5 kg	25 kg	50 kg	
MULTITOP	●	●	●	–	●
MULTI2	●	●	●	–	●
MULTI3	●	●	●	–	●
LOAD150	–	●	–	●	–
LOAD220	–	●	●	–	●
LOAD400	●	●	●	●	●
LOAD460	●	●	●	●	●
LOAD1000	●	–	●	●	●
TEMP90	●	–	●	–	●
TEMP110	–	–	–	●	–
TEMP120	●	–	●	–	–
SPEED2,6	–	–	●	–	–
VIB3	●	–	●	●	–
FOOD2	–	●	●	–	–
CLEAN-M	–	●	●	–	–
MOTION2	●	●	●	●	–

¹⁾ Other containers are available by agreement.

Further information

- TPI 168, Rolling Bearing Greases Arcanol
- Enquiries:
industrial-services@schaeffler.com, +49 2407 9149-66.



Product overview Lubrication devices

**Automatic
relubrication devices**
Lubricators
Lubrication systems



Lubrication system
for spindle bearings



Chain lubrication pinion
Lubrication gear



Pistol grease guns



Grease pumps

Drum pumps

Bearing-specific greasing tool

ARCA-PUMP-BARREL



TOOL-RAILWAY-GREASER



Lever grease guns

ARCA-GREASE-GUN



Lubrication devices

Features Rolling bearings are automatically provided with the correct quantity of lubricant by lubricators and lubrication systems. This prevents the most frequent cause of rolling bearing failure: inadequate or incorrect lubrication. Approximately 90% of bearings are lubricated with grease. Relubrication with the correct quantity of grease at the appropriate intervals gives a significant increase in the life of rolling bearings. For manual relubrication, grease guns are suitable.

Automatic relubrication devices

Automatic relubrication devices convey fresh lubricant in the defined quantity at the correct time to the contact points of the rolling bearing. The devices adhere to the lubrication and maintenance intervals and prevent undersupply or oversupply of grease. Plant downtime and maintenance costs are reduced as a result.

The relubrication devices are matched to the bearing positions. They have a wide range of applications, for example on electric motors, pumps, compressors and fans, in linear systems, conveying equipment or machine tools.

Lubricator CONCEPT2

This lubricator of protection class IP54 has a very compact design. It has one or two pump bodies that can be individually controlled, depending on the design. This means it can supply one or two lubrication points with lubricant. LC units are available in the size 250 cm³. The lubricator is supplied with voltage either from a battery or via a mains power pack, see table, page 79. It can work independently or can be optionally controlled by an external control system.

- Advantages** The advantages of the lubricator are as follows:
- easy operation and good overview
 - supply of up to two lubrication points
 - facility for setting different lubrication intervals for each lubrication point
 - supply of set lubricant quantity independent of temperature
 - counterpressure measurement up to the lubrication point
 - reliable piston pump as delivery pump
 - low ongoing maintenance costs
 - favourable price/performance ratio
 - operating temperature from –20 °C to +70 °C
 - battery or mains operation (DC 24 V) possible
 - pressure build-up to 50 bar (mains operation) or 30 bar (battery operation)
 - differentiated alarm messages
 - simple coupling with machine operation possible
 - suitable for control via an external control system.



**Available lubricators
CONCEPT2**

Designation	Design
CONCEPT2-1P	Battery version with one outlet
CONCEPT2-2P	Battery version with two outlets
CONCEPT2-1P-24VDC	24-V version with one outlet
CONCEPT2-2P-24VDC	24-V version with two outlets

Available LC units

Designation	
ARCALUB-C2.LC250-MULTITOP	ARCALUB-C2.LC250-TEMP90
ARCALUB-C2.LC250-MULTI2	ARCALUB-C2.LC250-TEMP110
ARCALUB-C2.LC250-LOAD150	ARCALUB-C2.LC250-TEMP120
ARCALUB-C2.LC250-LOAD220	ARCALUB-C2.LC250-TEMP200
ARCALUB-C2.LC250-LOAD400	ARCALUB-C2.LC250-SPEED2,6
ARCALUB-C2.LC250-LOAD460	ARCALUB-C2.LC250-MOTION2
ARCALUB-C2.LC250-LOAD1000	ARCALUB-C2.LC250-FOOD2
–	ARCALUB-C2.LC250-CLEAN-M

Further information LC units are also available by agreement with other greases.

Lubrication devices

Lubrication system CONCEPT8

This single-point and multi-point lubrication system offers high flexibility. It has one, two, three or four pump bodies that can be individually controlled, depending on the design. Each pump body has two outlets and, as a result, up to eight lubrication points can be flexibly provided with the required quantity of lubricant in the correct lubrication interval using just one lubrication system.

The lubrication system CONCEPT8 is designed for a wide variety of operating conditions. Designs for linear systems, the use of oils as lubricant or with an internal heating facility are also available, see table Available lubrication systems, page 81. Lubricant cartridges (LC units) provide the device with lubricant, see table Available LC units, page 81. LC units are available in the size 800 cm³.

The lubrication system is supplied with voltage from a mains power pack. Coupling with machine operation is possible if the voltage supply to machine and lubrication system is coupled, then the relubrication interval will always be dependent on the number of operating hours.

Advantages

The advantages of the lubrication system are as follows:

- easy operation and good overview
- suitable for oil and grease up to NLGI 3
- supply of up to eight lubrication points
- supply of set lubricant quantity independent of temperature
- counterpressure measurement up to the lubrication point
- reliable piston pump as delivery pump
- favourable price/performance ratio
- operating temperature from -20 °C to +70 °C
- facility for setting different lubrication intervals and lubricant quantities for each pump body
- low operating voltage of DC 24 V
- pressure build-up to 70 bar
- differentiated alarm messages
- simple coupling with machine operation possible
- suitable for control via an external control system.

**Available lubrication systems
CONCEPT8**

Designation	
CONCEPT8-1P	CONCEPT8-1P-CC
CONCEPT8-2P	CONCEPT8-2P-CC
CONCEPT8-3P	CONCEPT8-3P-CC
CONCEPT8-4P	CONCEPT8-4P-CC
CONCEPT8-1P-LIN	CONCEPT8-1P-OIL
CONCEPT8-2P-LIN	CONCEPT8-2P-OIL
CONCEPT8-3P-LIN	CONCEPT8-3P-OIL
CONCEPT8-4P-LIN	CONCEPT8-4P-OIL

LIN = for linear applications
 CC = with internal heating facility
 OIL = oil version

Available LC units

Designation	
ARCALUB-C8.LC800-MULTITOP	ARCALUB-C8.LC800-TEMP90
ARCALUB-C8.LC800-MULTI2	ARCALUB-C8.LC800-TEMP110
ARCALUB-C8.LC800-MULTI3	ARCALUB-C8.LC800-TEMP120
ARCALUB-C8.LC800-LOAD150	ARCALUB-C8.LC800-TEMP200
ARCALUB-C8.LC800-LOAD220	ARCALUB-C8.LC800-SPEED2,6
ARCALUB-C8.LC800-LOAD400	ARCALUB-C8.LC800-VIB3
ARCALUB-C8.LC800-LOAD460	ARCALUB-C8.LC800-MOTION2
ARCALUB-C8.LC800-LOAD1000	ARCALUB-C8.LC800-FOOD2
–	ARCALUB-C8.LC800-CLEAN-M

Further information

- LC units are also available by agreement with other greases or with oils
- Other accessories available by agreement
- Enquiries:
industrial-services@schaeffler.com, +49 2407 9149-66.

Lubrication devices

Minimal quantity lubrication devices

The compact lubrication systems allows very precise and efficient supply of lubricant to spindle bearings.

Grease lubrication system for spindle bearings

The grease lubrication system for spindle bearings is specially designed in terms of the delivery volume per stroke for the greasing of main spindles, see table.

Hoses filled with grease are connected to the outlets. These constitute the lubricant reservoir for relubrication. The cartridge only contains a pressure agent that is pumped into the hoses during delivery. The lubricant and pressure agent are separated from each other by a ball in the hose.

The lubricant is only subjected to pressure during the relubrication process in order to prevent separation of the grease.

Advantages

The advantages of the lubrication system are:

- optimum relubrication of the main spindles by means of very small quantities
- prevention of impermissible temperature increases
- suitable for bearings with different lubrication requirements
- simple coupling with machine operation possible
- favourable price/performance ratio.

Available grease lubrication system for spindle bearings

Designation	Outlet ducts	Delivery quantity per outlet duct cm ³ /stroke
	Quantity	
CONCEPT-PRECISION-GREASE	2	0,023

**Oil lubrication system
for spindle bearings**

Spindle bearings run at high speeds. For this reason, pneumatic oil lubrication has previously been used for speed parameters above 1 600 000 mm/min. This requires extremely clean, dry compressed air. The high costs of this compressed air are not incurred with direct oil lubrication. The compressed air is replaced by a damper throttle element. This element gives an almost continuous delivery rate. Two systems are available, see table. One version has an internal oil tank, while the other is supplied via a connection adapter for an external oil tank.

Advantages

The advantages of the lubrication system are:

- optimum relubrication of main spindles by means of very small quantities at a constant delivery rate
- suitable for bearings with different lubrication requirements
- simple coupling with machine operation possible
- no compressed air costs for bearing lubrication
- no risk of spindle failure due to inadequate air cleanliness
- favourable price/performance ratio.

**Available oil lubrication system
for spindle bearings**

Designation	Oil tank cm ³
CONCEPT-PRECISION-OIL-250	250
CONCEPT-PRECISION-OIL	–



Lubrication devices

Chain lubrication pinion

A chain lubrication pinion is used to supply chains with chain oil according to requirements and fully automatically. The rollers are made from open cell PU foam and transfer very small quantities of oil to the highest points on the chain links. From there, the oil passes between the inner and outer links and between the pins and rollers. There is no coating of other surfaces of the chain with oil, which is unnecessary and in many case undesirable.

The chain pinion segments are made from special plastic and convert the linear (translation) movement of the chain into rotary motion (rotation) of the chain lubrication pinion. Despite the non-uniform surface of the chain links, the co-rotation of the plastic pinion ensures very quiet running of the lubrication pinion even at very high speeds.

Chain lubrication pinions are available for standard chains, simplex, duplex, triplex and also special chains.

Lubrication gear

A lubrication system comprises a lubrication gear and drive pinion or a lubrication gear and toothed rack. The lubrication gear gives automatic, continuous relubrication of the open tooth sets of the drive pinion or toothed rack.

A lubrication gear is connected to the drive pinion or toothed rack. The lubrication gear, made from open cell PU foam, stores the lubricant and transfers it in very small metering quantities to the tooth set in contact. This facilitates optimum supply to the tooth sets over very long periods and prevents both overlubrication as well as wear due to lubricant starvation.

A lubrication gear does not transmit either force or torque.

The following tooth sets are available:

- straight teeth
- helical teeth, helix angle up to 45°
- modulus: 2 to 30
- width: up to 700 mm.

Pistol grease gun The pistol grease gun has a 4 digit digital counter that displays the lubricant quantity in grams. The specific mass of the lubricant can be set.

Ordering designation **ARCA-PUMP-BARREL.GUN-METER**

The features of the pistol grease gun are as follows:

- measurement range: 0,1 g to 1000 g
- display of gram counter: 4 digits
- display of total counter (kg): 4 digits
- maximum operating pressure: 600 bar
- burst pressure: 1000 bar
- maximum operating temperature: +60 °C
- tolerance: $\pm 3\%$ of displayed value
- battery life: 24 months
- inlet: z type swivel joint G^{1/4}
- outlet: nozzle tube with 4 jaw nozzle
- mass: 1,7 kg.



Lubrication devices

Grease pumps Grease pumps are driven by pneumatic or manual means.

Drum pumps Drum pumps ARCA-PUMP-BARREL, see table, are pneumatically driven and suitable for delivering large quantities of grease under high pressure over long distances. Drum pumps can be used either as delivery pumps for individual greasing stations or as a supply pump for central lubrication systems.

Available drum pumps

Designation	Pump ratio	Delivery rate at 6 bar g/min	Air consumption l/min	Suitable for container sizes kg
ARCA-PUMP-BARREL-25-S	70:1	1 100	150	25
ARCA-PUMP-BARREL-50-S	70:1	1 100	150	50
ARCA-PUMP-BARREL-180-S	70:1	1 100	150	180

The following accessories are available for the drum pumps: drum cover (dust cover), follower plate, high pressure delivery hoses and pistol grease guns.

Bearing-specific greasing tools In the reconditioning of wheel bearing sets for rail vehicles (TAROL units), rapid and uniform greasing can be achieved by means of bearing-specific greasing tools. The tool is connected to a drum pump that supplies the appropriate grease quantity.

Ordering example
Ordering designation

Greasing tool for bearing F-561775
TOOL-RAILWAY-GREASER-F-561775

Further information

- TPI 156, Tapered Roller Bearing Units TAROL – Mounting, Maintenance, Repair
- Enquiries:
industrial-services@schaeffler.com, +49 2407 9149-66.

Lever grease gun and reinforced hose

The lever grease gun, see table, can be used to manually relubricate rolling bearings via lubrication nipples.

The container on the lever grease gun can be filled with 500 g loose grease or with a 400-g cartridge. The cartridge must conform to DIN 1284 (diameter 53,5 mm, length 235 mm).

The lever grease gun is connected to the lubrication nipple via a reinforced hose. The reinforced hose must be ordered separately, see table. The connector thread is G¹/₈. The reinforced hose has a hydraulic grip coupling for connection to the taper type lubrication nipple in accordance with DIN 71412.

Alternatively, the reinforced hose can be fitted with a connector for cylindrical lubrication nipples in accordance with DIN 3404.

In place of the hydraulic grip coupling, slide couplings for button head lubrication nipples in accordance with DIN 3404 or other nozzles can be connected. These connectors are available from normal trade outlets.

Available lever grease guns

Designation	Maximum delivery pressure bar	Delivery quantity per stroke cm ³
ARCA-GREASE-GUN	800	2



Available reinforced hoses

Designation	Length mm	Connector
ARCA-GREASE-GUN.HOOK-ON-HOSE	300	Cylindrical lubrication nipples with head 16 mm in accordance with DIN 3404
ARCA-GREASE-GUN.HOSE	300	Taper type lubrication nipples in accordance with DIN 71412



Products: Condition Monitoring



Products: Condition Monitoring

	Page
Alignment	
Product overview	92
Features	
Belt pulley alignment device Top-Laser SMARTY2.....	93
Belt tension measuring device Top-Laser TRUMMY2.....	95
Shaft alignment device Top-Laser EQUILIGN.....	97
Shims Top-Laser SHIM	102
Vibration diagnosis	
Product overview	104
Features	
Monitoring devices – offline and online	105
Worldwide service.....	105
Vibration measuring device Detector III	105
Online monitoring system SmartCheck	108
Online monitoring system SmartQB	110
Online monitoring system DTECT X1 _s	114
Online monitoring system WiPro _s	115
Online monitoring system ProCheck	116
Other monitoring systems	116
Monitoring of lubricants	
Product overview	118
Features	
Grease sensor GreaseCheck	119
Particle sensor Wear Debris Check.....	120



Product overview Alignment

Belt pulley alignment device
Top-Laser SMARTY2
Belt tension measuring device
Top-Laser TRUMMY2

LASER-SMARTY2



LASER-TRUMMY2



Shaft alignment device
Top-Laser EQUILIGN
Shims
Top-Laser SHIM

LASER-EQUILIGN



LASER-SHIM



Alignment

Features

These products assist in the alignment of shafts and belt pulleys and the checking of belt tension values.

Belt pulley alignment device FAG Top-Laser SMARTY2

The FAG Top-Laser SMARTY2 is a line laser for the alignment of belt pulleys and chain sprockets with a diameter of more than 60 mm. The alignment of belt pulleys and chain sprockets reduces wear and energy losses in tension drives, their bearings and seals. Less heat is generated and the lifetime and reliability of the machines is increased.

The features of the line laser are as follows:

- The parallelism and angular errors of the two pulleys are displayed.
- Alignment can be carried out on both horizontally and vertically mounted belt pulleys.
- Alignment is significantly more rapid and more precise than with conventional methods.
- Alignment can be carried out by one person working alone.
- The measuring device is attached to the pulleys by magnetism.

The laser can be clearly seen on the target marks. Once the machine is adjusted such that the laser beam coincides with the slots in the target marks, it is correctly aligned.

The target marks are available in an optical, *Figure 2*, page 94, and an electronic design, *Figure 1* and *Figure 3*, page 94. In the case of electronic target marks, the adjustment values are displayed in real time on the digital display. Angular errors are shown in degrees, while the parallelism offset is shown in millimetres.

Caution 

Do not look into the laser beam or point the laser beam into another person's eyes.



Figure 1
Electronic target mark



Alignment

All the parts are supplied in a lined case, *Figure 2*.

- Scope of delivery
- 1 emitter
 - 2 optical target marks, attached by magnetism
 - 1 battery
 - 1 lined case

Ordering designation **LASER-SMARTY2**

- ① Emitter
- ② Optical target mark
- ③ Battery
- ④ Lined case

Figure 2
Scope of delivery
FAG Top-Laser SMARTY2



- Replacement part
- 1 optical target mark, attached by magnetism

Ordering designation **LASER-SMARTY2.TARGET**

- Accessories
- 1 electronic target mark, attached by magnetism
 - 1 case

Ordering designation **LASER-SMARTY2.TARGET-DIGITAL**

- ① Electronic target mark
- ② Case

Figure 3
Scope of delivery
FAG Top-Laser TARGET-DIGITAL



**Belt tension measuring device
FAG Top-Laser TRUMMY2**

The robust, handy FAG Top-Laser TRUMMY2 is an optical-electronic manual measuring instrument for belt tension (strand force).

The correct belt tension is an essential prerequisite for achieving the maximum life of the belt drive. In addition, this gives reduced wear of the drive components, lower energy costs and increased cost-efficiency.

The FAG Top-Laser TRUMMY2 comprises a cableless measurement probe for direct connection, a measurement probe with cable for difficult to access locations and a manual control device that displays the relevant measurables for belt tension as a frequency in Hz or force in N.

Caution 

Do not look into the laser beam or point the laser beam into another person's eyes.

The simple and reliable user instructions are given in several languages.

All the parts of the belt tension measuring device are supplied packed in a case, *Figure 4*.

Scope of delivery 1 manual control device
1 measurement probe for direct connection
1 measurement probe with cable
1 case

Ordering designation **LASER-TRUMMY2**



- ① Manual control device
- ② Measurement probe, direct connection
- ③ Measurement probe, cable connection
- ④ Case



Figure 4
Scope of delivery
FAG Top-Laser TRUMMY2

The belt tension measuring device should be calibrated at least every 2 years. The FAG Top-Laser TRUMMY2 should be sent to us for this purpose.

Service Calibration
Ordering designation **LASER-TRUMMY.CALI-CHECK**

Alignment

Application Before calculating the belt tension, the belt mass and length must be entered. Vibration of the belt is then induced. The device measures the natural frequency by means of clock pulse light and uses this to determine the belt tension, *Figure 5*. This technique is less prone to disruptive influences in comparison with measurement using sound waves.



- ① Belt
- ② TRUMMY2, cableless measurement probe

Figure 5
Measurement

Shaft alignment device FAG Top-Laser EQUILIGN

The FAG Top-Laser EQUILIGN, *Figure 6*, is an alignment system for coupled and decoupled shafts in motors, pumps, ventilators and gearboxes with rolling bearings.

The advantages of the system are:

- simple mounting
- error-free handling even by untrained personnel using step-by-step display on the manual control device
- automatic tolerance checking.
A symbol indicates when the shafts are correctly aligned
- more precise alignment than with conventional methods
- rapid, simple measurement by means of Active Clock measurement mode
- robust control device.
Watertight and insensitive to contamination in accordance with IP 65
- user interface in 20 languages
- easy generation of reports
- real time display of displacement in all axes.

Caution 

Do not look into the laser beam or point the laser beam into another person's eyes.



Figure 6
Shaft alignment device
FAG Top-Laser EQUILIGN

Alignment

All the parts of the shaft alignment device are supplied packed in a case, *Figure 7*.

- | | |
|-------------------|---|
| Scope of delivery | 1 manual control device
1 emitter and receiver including cable 2 m long
1 reflector
5 batteries
1 Allen key
1 cable for connecting USB memory stick to device
1 cable for connecting device to PC via USB port
2 brackets
2 chains, 300 mm long
4 posts, 115 mm long
1 tape measure
1 case |
|-------------------|---|

Ordering designation **LASER-EQUILIGN**

- | |
|--|
| ① Manual control device |
| ② Emitter/receiver |
| ③ Reflector |
| ④ Batteries, LR6 (AA) DC 1,5 V, 5 pieces |
| ⑤ Allen key, 4 mm |
| ⑥ Cable for USB memory stick |
| ⑦ Cable for PC |
| ⑧ Bracket |
| ⑨ Chain, 300 mm long |
| ⑩ Post, 115 mm long |
| ⑪ Tape measure |
| ⑫ Case |

Figure 7
Scope of delivery
FAG Top-Laser EQUILIGN



Replacement parts

Designation	Description	Scope of delivery Quantity
LASER-EQUILIGN-DEVICE	Manual control device	1
LASER-EQUILIGN.TRANS	Emitter/receiver with cable	1
LASER-EQUILIGN.REFLECT	Reflector	1
LASER-EQUILIGN.USB-CABLE	Cable for USB memory stick, 2 m long	1
LASER-EQUILIGN.PC-CABLE	Cable for PC, 2 m long	1
LASER.BRACKET	Bracket	2
LASER.CHAIN300-SET	Chain, 300 mm long	2
LASER.POST115-SET	Post, 115 mm long	4
LASER.TAPE	Tape measure, 1 m long	1
LASER-EQUILIGN.CASE	Case	1

Comprehensive range of accessories

A comprehensive range of accessories is available in order to expand the possible applications of the base device FAG Top-Laser EQUILIGN.

The accessories can be ordered as a set in a handy, robust case or as individual parts.

Accessories, individual parts

Designation	Description	Scope of delivery Quantity
LASER.CHAIN600-SET	Chain, 600 mm long	2
LASER.CHAIN1500-SET	Chain, 1 500 mm long	2
LASER.POST150-SET	Post, 150 mm long	4
LASER.POST200-SET	Post, 200 mm long	4
LASER.POST250-SET	Post, 250 mm long	4
LASER.POST300-SET	Post, 300 mm long	4
LASER.BRACKET-MAGNET	Magnetic holder including 2 posts, 150 mm long	1



Alignment

Accessories, set

Designation	Description	Scope of delivery Quantity
LASER.ACCESS-SET	Chain, 600 mm long	2
	Chain, 1500 mm long	2
	Post, 150 mm long	4
	Post, 200 mm long	4
	Post, 250 mm long	4
	Post, 300 mm long	4
	Magnetic holder including 2 posts, 150 mm long	2
	Case	1

- ① Chains, 600 mm
- ② Chains, 1500 mm
- ③ Posts, 150 mm
- ④ Posts, 200 mm
- ⑤ Posts, 250 mm
- ⑥ Posts, 300 mm
- ⑦ Magnetic holder
- ⑧ Case

Figure 8
Accessories, set



000151000

Alignment

Before alignment is carried out, any soft foot must be eliminated. FAG Top-LaserEQUILIGN clearly indicates the soft foot. Each individual screw foot connection is loosened and the device is monitored to see if it displays any changes between the foot screwed firmly into place and the loosened foot. The soft foot can then be eliminated using shims. This eliminates any tendency towards vibration and bearing damage as a result of housing deformation. During measurement, at least three positions are approached at different angles. These must be measured at an angle of at least 90°. The intelligent control system prevents incorrect usage here. The actual condition of the subassembly is then displayed, *Figure 9*.

- ① Display of actual condition
- ② Foot screw connection
- ③ Direction of vertical displacement
- ④ Direction of horizontal displacement

Figure 9
Alignment



Once the foot screw connections have been loosened, the vertical misalignment is first eliminated by means of shims. FAG Top-LaserEQUILIGN shows the displacement in real time. This means that the user can monitor on the display how the measurement results change as soon as the subassembly is moved. Horizontal adjustment is then carried out until the symbol with the thumb pointing upwards is displayed. Once the foot screw connections are tightened, the shafts are aligned.

Alignment

Shims FAG Top-Laser SHIM

Shims FAG Top-Laser SHIM are used to eliminate vertical misalignment or soft feet.

These shims are made from corrosion-resistant high grade steel and are available in seven thicknesses (0,05 mm, 0,1 mm, 0,2 mm, 0,5 mm, 0,7 mm, 1 mm, 2 mm) and in four sizes (dimension $c = 15$ mm, 23 mm, 32 mm, 44 mm), *Figure 10* and table, page 103.

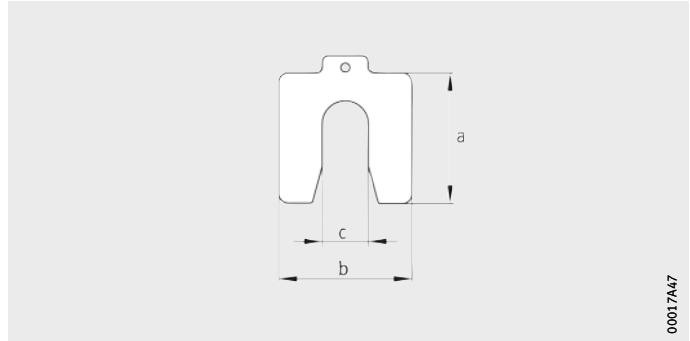

Figure 10
Shim, dimensions

Scope of delivery Basic set	Case 360 shims: 20 shims each in 3 sizes (dimension $c = 15$ mm, 23 mm, 32 mm) and 6 thicknesses (0,05 mm to 1 mm) 1 extraction hook
Ordering designation	LASER.SHIM-SET
Replacement parts	As replacement parts, we can supply 10 shims each in one of the 4 sizes and one of the 7 thicknesses stated above.
Ordering example 1 Ordering designation	10 shims of dimension $c = 15$ mm and thickness 0,2 mm LASER.SHIM15×0,20
Ordering example 2 Ordering designation	10 shims of dimension $c = 44$ mm and thickness 0,1 mm LASER.SHIM44×0,10

Available shims

Designation	Mass m g	Dimensions in mm			
		a	b	c	Thickness
LASER.SHIM15×0,05	11	55	50	15	0,05
LASER.SHIM15×0,10	22	55	50	15	0,1
LASER.SHIM15×0,20	44	55	50	15	0,2
LASER.SHIM15×0,50	110	55	50	15	0,5
LASER.SHIM15×0,70	155	55	50	15	0,7
LASER.SHIM15×1,00	220	55	50	15	1
LASER.SHIM15×2,00	440	55	50	15	2
LASER.SHIM23×0,05	21	75	70	23	0,05
LASER.SHIM23×0,10	42	75	70	23	0,1
LASER.SHIM23×0,20	84	75	70	23	0,2
LASER.SHIM23×0,50	210	75	70	23	0,5
LASER.SHIM23×0,70	295	75	70	23	0,7
LASER.SHIM23×1,00	420	75	70	23	1
LASER.SHIM23×2,00	840	75	70	23	2
LASER.SHIM32×0,05	29	90	80	32	0,05
LASER.SHIM32×0,10	58	90	80	32	0,1
LASER.SHIM32×0,20	115	90	80	32	0,2
LASER.SHIM32×0,50	290	90	80	32	0,5
LASER.SHIM32×0,70	410	90	80	32	0,7
LASER.SHIM32×1,00	580	90	80	32	1
LASER.SHIM32×2,00	1 160	90	80	32	2
LASER.SHIM44×0,05	53	125	105	44	0,05
LASER.SHIM44×0,10	106	125	105	44	0,1
LASER.SHIM44×0,20	212	125	105	44	0,2
LASER.SHIM44×0,50	530	125	105	44	0,5
LASER.SHIM44×0,70	742	125	105	44	0,7
LASER.SHIM44×1,00	1 050	125	105	44	1
LASER.SHIM44×2,00	2 100	125	105	44	2



Further information

- TPI 182, FAG Alignment Tools – Top-Laser: SMARTY2 · TRUMMY2 · EQUILIGN · SHIM
- Enquiries: industrial-services@schaeffler.com, +49 2407 9149-66.

Product overview Vibration diagnosis

Vibration measuring device Detector III

DETECT3-KIT, DETECT3-KIT-RFID, DETECT3.BALANCE-KIT



Online monitoring system SmartCheck SmartQB

SMART-CHECK



SMART-QB



Online monitoring system DTECT X1_s WiPro_s

DTECTX1-S, DTECTX1-S-WIPRO



Online monitoring system ProCheck

PRO-CHECK



Vibration diagnosis

Features Vibration diagnosis is the most reliable method for identifying the start of machine damage at an early stage. Unbalance and misalignment defects can be detected accurately, as well as rolling bearing damage and gear tooth defects.

FAG vibration measuring devices help in planning maintenance work, increasing bearing life and reducing costs. As a result, plant availability is increased and the risk of unplanned downtime is reduced.

Monitoring devices – offline and online In the field of offline monitoring devices (regular monitoring), Schaeffler offers the FAG Detector III.

The online monitoring systems (continuous measurement) include FAG SmartCheck, FAG DTECT X1_s, FAG WiPro_s and FAG ProCheck.

In order to achieve optimum networking to plant control facilities or monitoring centres, all online systems have versatile communication options as standard.

Worldwide service On all devices relating to condition monitoring, Schaeffler offers a worldwide service – from the customer hotline to customer-specific service contracts.

**Vibration measuring device
FAG Detector III** FAG Detector III is a handy, easy to use vibration measuring device. Preinstalled standard configurations in accordance with DIN ISO 10816 make this a Plug-and-Play solution and allow authoritative information on the machinery condition, entirely without time-consuming training or system configuration.

This allows, for example, rapid inspection of ventilators, pumps, electric motors, compressors or vacuum pumps. All the user must do is start the measurement process by pressing a few buttons and wait until it is completed. The device evaluates the measurement results and presents the results, with self-explanatory symbols, on the device display, *Figure 1*.



- ① Value OK
- ② Prealarm
- ③ Main alarm



Figure 1
Symbols in the device display

Vibration diagnosis

The system also has the following features:

- non-contact temperature measurement
- speed detection
- route function
- report generator.

Analysis software

For more detailed analysis, the PC software Trendline is available free of charge and includes comprehensive functions.

These include the Viewer, which gives the user a wide range of tools for data evaluation. The integrated rolling bearing database, containing approximately 20 000 bearings from various manufacturers, facilitates easier and more efficient analysis of the measured data. Since the damage frequencies can be incorporated in the measurement results, simple damage analysis is possible.

Automatic detection of measurement points

The automatic detection of measurement points through the use of RFID technology gives error-free and precise identification of the measurement points on a measurement route. FAG Detector III identifies the measurement points by means of RFID tags on the machinery. With the proven FAG Detector III, mobile vibration and temperature monitoring is thus quicker, simpler and more reliable. The functionality of automatic measurement point detection is not available worldwide.

Further information

- Enquiries:
industrial-services@schaeffler.com, +49 2407 9149-66.

Balancing function

A further special feature of FAG Detector III is the balancing function. For this purpose, the optionally available Balancing Kit is required. This makes it possible to not only detect but also eliminate unbalances.

The results of the balancing process are also transferred to the Trendline software for evaluation.

Ordering examples	The vibration measuring device FAG Detector III is available in two variants, with the balancing function available for ordering in a upgraded version.
Scope of delivery Base device	1 base device with rechargeable battery 1 accelerometer, attached by magnetism, and sensor cable 1 infrared temperature sensor 1 charger with worldwide compatibility 1 PC data cable (serial and USB) 1 user manual 1 protective bag with holder for temperature sensor 1 Trendline PC software free of charge 1 case
Ordering designation	DETECT3-KIT
Scope of delivery Device with automatic measurement point detection	As DETECT3-KIT 1 RFID reader (integrated) 5 RFID tags for identifying the measurement point
Ordering designation	DETECT3-KIT-RFID
Scope of delivery Upgrade level with balancing function	1 accelerometer, attached by magnetism, and sensor cable 1 trigger sensor, optical 1 trigger sensor, induction 1 reflective mark for trigger sensor 1 cable for trigger sensor, 10 m 1 magnetic holder for trigger sensor 1 extension for magnetic holder 1 balance 1 dongle for activation of balancing function 1 case
Ordering designation	DETECT3.BALANCE-KIT
Accessories	Sensor extension cables with a length of 5 m or 15 m are available by agreement. The charging dock, mounting pads and additional RFID tags are available by agreement.
Further information	■ TPI WL 80-64, FAG Detector III – The Solution for Monitoring and Balancing or www.FAG-DetectorIII.de ■ Enquiries: industrial-services@schaeffler.com , +49 2407 9149-66.



Vibration diagnosis

Online monitoring system FAG SmartCheck

FAG SmartCheck is a compact, innovative, modular online measuring system for continuous monitoring of machinery and process parameters on a decentralised basis. It can be used on assemblies where such monitoring was previously too cost-intensive.

FAG SmartCheck is suitable, for example, for early detection of rolling bearing damage, unbalances and misalignments on:

- electric and geared motors
- vacuum and fluid pumps
- ventilators and fans
- gearboxes and compressors
- spindles and machine tools
- separators and decanters.

Plug-and-Play system

FAG SmartCheck is ready for immediate use. When supplied, it already has a set of key data that facilitate general, reliable machinery monitoring.

In addition, predefined configuration templates are available for monitoring of items such as fans, pumps and bearings. These can easily be matched to individual requirements. Due to the integrated bearing database of FAG and INA standard bearings, data configuration and later analysis are simpler. The system has an independent teaching mode that identifies the alarm thresholds.

Parameters monitored

In addition to the standard parameters of vibration and temperature, it is possible to record other classic operating parameters such as pressure or flow rate. All parameters can be correlated with each other and included in the alarm configuration.

The data are recorded and analysed centrally by the system. The current machine condition can be displayed directly on the device or transferred to any control facility as required. It is only necessary to integrate FAG SmartCheck in the existing network structure.

Mitsubishi control system

General communication with controllers can be carried out through connection of the analogue and digital interfaces with the controller. The communication protocol SLMP has been implemented specially for Mitsubishi controllers of the L and Q series. This allows direct transfer of the measurables status and gives information, for example, on rolling bearing damage, unbalance, misalignments or temperature fluctuations that can be notified in plain text to the operator by means of the controller.

- Access via the Internet** FAG SmartCheck has an intuitive user concept designed as a Web interface. It is therefore possible to access the system via the Internet using any standard Internet browser. The Web interface can be used to configure the system and view current data.
- Remote monitoring** The data can be transferred to other locations by remote access and analysed there by the operator or external service providers such as the Schaeffler vibration experts. This is particularly important for customers who still have little experience of data analysis or wish to outsource this function.
- Further information**
- TPI 214, FAG SmartCheck or www.FAG-SmartCheck.de
 - Enquiries:
industrial-services@schaeffler.com, +49 2407 9149-66.



Vibration diagnosis

Online monitoring system FAG SmartQB

FAG SmartQB is an easy way to get started in Condition Monitoring. It monitors the vibrations in electric motors, pumps and fans. Commissioning can be carried out by an employee who does not have specific knowledge in the field of vibration diagnosis. The 7" display shows user-friendly plain text messages, *Figure 2*.

The features of FAG SmartQB are:

- suitable for machinery with fixed and variable speeds from 100 min^{-1} to $15\,000 \text{ min}^{-1}$
- preconfigured for up to six sensors
- touch panel with plain text messages
- minimal installation work using 1 cable technique (Power over Ethernet)
- live display of current values
- trend pattern of damage development
- user interface in 16 languages
- RJ45 Ethernet interface for service technicians.



Figure 2
Online monitoring system
FAG SmartQB

The scope of delivery comprises three parts, *Figure 3*.

- Scope of delivery 1 housing with sensor unit FAG SmartQB with 7" touch panel
 1 FAG SmartQB sensor 1
 1 Ethernet cable, 10 m long
- Ordering designation **SMART-QB**

- ① Housing
- ② Sensor
- ③ Ethernet cable

Figure 3
 Scope of delivery
 Online monitoring system
 FAG SmartQB



Replacement parts

Designation	Description	Scope of delivery Quantity
SMART-QB.SENSOR-1	Sensor 1	1
SMART-CHECK.CABLE-ETH-P-M12-RJ45-10M	Ethernet cable, 10 m long	1



Vibration diagnosis

Installation and commissioning

In addition, installation and commissioning are exceptionally simple. Any industrial electrician can install the system and, without prior knowledge of vibration technology, can carry out commissioning within five minutes.

The touch display gives personnel all relevant information, from mounting through recommended actions in the case of errors. At first startup, the customer selects one of 16 languages and, where necessary, replaces the preset contact details for technical support from Schaeffler with his own information.

After selection of the machine (electric motor, pump or fan) to which the FAG SmartQB Sensor is attached and the category “variable speed machine” or “constant speed machine” and input of the individual machine name, the FAG SmartQB automatically selects the best measurement configuration and the system is immediately ready for teach-in mode. This runs automatically.

A maximum of six sensors can be connected to one FAG SmartQB. Each sensor can monitor a different machine. New sensors can also be added using the menu just as easily as in first installation.

After commissioning, the FAG SmartQB shows relevant information for each sensor on the display.

Examples include:

- alarm status
- vibration values
- defect frequency
- maximum values
- mean values
- trend patterns.

Defect causes

The Condition Monitoring system can detect a total of five defect causes and output these on the display:

- bearing damage
- unbalance
- friction/cavitation
- increases in temperature
- significant changes in the vibration patterns.

Due to the automated allocation of defects, the maintenance personnel no longer require knowledge of vibration technology. Maintenance measures and any ordering of replacement parts as necessary can be immediately initiated through defect allocation.

Market sectors

FAG SmartQB is typically used in the following sectors:

- cement
- paper
- steel
- water management
- machinery and equipment building
- repair shops for electric motors, pumps and fans.

FAG SmartQB is optimised for use in these sectors and is supplied already configured. Due to the automated defect allocation, maintenance measures and any ordering of replacement parts as necessary can be immediately initiated.

Comprehensive range of accessories

An extensive range of accessories is available to expand the possible applications of the monitoring system FAG SmartQB, see table and *Figure 4*. The accessories can be ordered as individual items.

Accessories, individual parts

Designation	Description	Scope of delivery Quantity
SMART-QB.SENSOR-2	Sensor 2	1
SMART-QB.SENSOR-3	Sensor 3	1
SMART-QB.SENSOR-4	Sensor 4	1
SMART-QB.SENSOR-5	Sensor 5	1
SMART-QB.SENSOR-6	Sensor 6	1
SMART-CHECK.CABLE-ETH-P-M12-RJ45-20M	Ethernet cable, 20 m long	1
SMART-CHECK.CABLE-ETH-P-M12-RJ45-30M	Ethernet cable, 30 m long	1
SMART-QB.LAMP	Lamp incl. cable 2×10 m long	1



Figure 4
Accessories for FAG SmartQB

000A37F4

Vibration diagnosis

Online monitoring system FAG DTECT X1_s

FAG DTECT X1_s is a versatile online system for the monitoring of rotating components and elements in the machinery and plant industry. Typical applications can be found, for example, in the steel, raw materials, paper and marine industries.

The system gives early, reliable detection of possible damage and thus helps to prevent unplanned and expensive downtime. The risk of possible production shutdowns is reduced. As a result, the capacity utilisation of machinery and plant is increased.

Versatile system

The system can be tailored to customer-specific requirements by means of the software.

The base device has 8 measurement channels. All conventional acceleration, speed and travel sensors can be attached.

Due to its compact size and robust housing (protection class IP 67), it is suitable for a wide range of monitoring applications. It has standardised connectors allowing easy installation on machinery and plant.

Remote monitoring

Defects and damage can be detected on machinery without the need for a diagnosis expert on site. The data can be transferred to other locations by remote access and analysed there, for example by Schaeffler vibration experts.

Further information

- TPI 170, FAG DTECT X1_s
- Enquiries:
industrial-services@schaeffler.com, +49 2407 9149-66.

**Online monitoring system
FAG WiPro_s**

FAG WiPro_s allows online monitoring of wind farms – onshore and offshore. The system gives early and reliable detection of possible machine damage. This helps to prevent unplanned downtime and expensive secondary damage. Due to its small size, it can easily be accommodated in small spaces such as the nacelle of a wind turbine.

Versatile system

FAG WiPro_s is equipped with a signal processor and evaluates all measurement signals internally. Due to the intelligent linking of expert knowledge with information from the turbine, it is possible to keep the transferred data volume very small. This is particularly important where a large number of turbines must be continuously monitored over a long period.

Remote monitoring

The automatic messaging function by means of TCP/IP, wifi modem (optional), landline modem or DSL router allows efficient worldwide monitoring. The data can be transferred to other locations by remote access and analysed there, for example by Schaeffler vibration experts.

Further information

- WL 80 373, Flyer FAG WiPro_s
- Enquiries:
industrial-services@schaeffler.com, +49 2407 9149-66.



Vibration diagnosis

Online monitoring system FAG ProCheck	FAG ProCheck is a versatile online monitoring system. It can be used to prevent unplanned downtime and for quality control. The system offers a high level of functionality and is available in a range of variants – from an 8 channel to a 16 channel system.
Parameters monitored	<p>FAG ProCheck continuously records data on vibration, temperature and other process parameters and subsequently carries out their evaluation. As a result, incipient damage and its causes can be detected at a very early stage and the appropriate countermeasures can be introduced in good time. This gives a considerable reduction in operating costs.</p> <p>In addition, FAG ProCheck offers the possibility of correlating a large number of analogue and digital input and output signals to the vibration data. These channels also allow simple communication with higher level systems such as process control systems.</p>
Versatile system	Due to its extremely robust and compact design, this system is ideally suited for use in almost all industrial segments. The system can be used in steelworks, paper machinery, cement plants or in the oil and gas industry.
Remote monitoring	Defects and damage can be detected on machinery without the need for a diagnosis expert on site. The data can be transferred to other locations by remote access and analysed there, for example by Schaeffler vibration experts.
Explosion-protected variant	An explosion-protected version of FAG ProCheck is available by agreement. In this version, a specially pressure-encapsulated housing prevents the system coming into contact with an explosive atmosphere. This is because wherever flammable gases, vapours, fluids or dust occur, the presence of oxygen and an ignition source can rapidly cause an explosion.
Further information	<ul style="list-style-type: none">■ TPI WL 80-69, FAG ProCheck State of the Art Machine Monitoring for Maximum Availability■ Enquiries: industrial-services@schaeffler.com, +49 2407 9149-66.
Customer-specific solutions	The display, which is individually tailored to the customer's requirements, gives a user interface that allows a rapid overview of the condition of the plant. Depending on the complexity of the plant, this display can be arranged on several levels.
Other monitoring systems	Other monitoring systems for the requirements of specific sectors are available by agreement.



Product overview Monitoring of lubricants

Grease sensor GreaseCheck

GREASE-CHECK

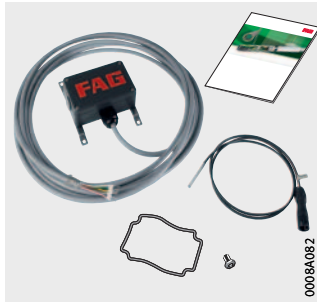

Particle sensor Wear Debris Check

WEAR-DEBRIS-CHECK



Monitoring of lubricants

Features The operating life of the lubricant is the decisive value for the bearing life. Depending on the application, either a grease or particle sensor can be used for monitoring. The lubricant can be topped up or replaced in good time before damage occurs.

Grease sensor FAG GreaseCheck

The grease sensor has a diameter of 5 mm and is inserted in a hole in the housing as close as possible to the rolling bearing. The sensor is positioned in the lubricant. This grease sensor optically measures the water content, the extent of grease deterioration and the grease temperature directly in the bearing arrangement. This information is transferred by cable to the evaluation unit, *Figure 1*. The evaluation unit generates an analogue signal and a digital system that gives the user rapid and simple information on the condition of the grease.

- ① Grease sensor
- ② Electronic evaluation system

Figure 1
Grease sensor and
electronic evaluation system



In the past, bearings were regreased as a function of time. The grease quantities and lubrication intervals were calculated numerically. If the grease sensor is used, regreasing can be carried out as a function of condition.



- Advantages** The grease sensor facilitates:
- lubrication appropriate to needs
 - lower lubricant costs
 - prevention of unplanned downtime
 - lower maintenance costs
 - lower equipment costs.

- Further information**
- TPI 234, Condition Monitoring of Greases in Rolling Bearings
 - Enquiries:
industrial-services@schaeffler.com, +49 2407 9149-66.

Monitoring of lubricants

Particle sensor FAG Wear Debris Check

Particle sensors of this type can be used to determine wear at an early stage in heavily loaded industrial gearboxes on the basis of particles in the oil. The debris particles that can indicate a failure can be detected in the oil several months in advance. Through monitoring of particles in the lubricant, damage is detected at an early stage. This helps to prevent secondary damage and downtime periods. The particle sensor is installed in an ancillary flow of the recirculating lubrication system in the gearbox ahead of the filter or in a separate circuit.

Typical applications for the FAG Wear Debris Check can be found, for example, in gearboxes in raw material extraction plant, planetary gearboxes in wind turbines or in ship propulsion systems.

The features of the particle sensor are as follows:

- monitoring of the number of particles in the oil
- differentiation of the particles into ferrous and non-ferrous metals
- classification of the particles according to size
- possible integration in an online monitoring system for linking of oil particle and vibration data.

Where oil and vibration monitoring facilities are combined, damage in gearboxes with recirculating oil lubrication can be detected at an early stage and the source can be determined. In this way, it is possible to prevent production shutdowns or secondary damage.

Further information

- WL 80 366, Flyer FAG Wear Debris Check
- Enquiries:
industrial-services@schaeffler.com, +49 2407 9149-66.





FAG



Services

Services

	Page
Features	
Mounting and dismounting.....	124
Lubrication.....	127
Condition Monitoring.....	128
Tools and measuring devices.....	134
Corrective maintenance.....	135
Rolling bearing reconditioning.....	136
Technical consultancy.....	139
TCO approach.....	141



Services

Features Schaeffler offers, irrespective of the manufacturer of the bearing arrangement, a wide range of services relevant to the lifecycle of a rolling bearing: starting with mounting and progressing through maintenance to the reconditioning of rolling bearings.

During the operational phase, the Schaeffler experts provide support through services in the fields of condition monitoring and corrective maintenance. Companies that wish to build up their knowledge in the areas of rolling bearings and condition monitoring also have access to the Schaeffler training and consultancy portfolio on site, centrally or online. Our e-learning portfolio on the Internet provides an introduction to this field. In this way, customers benefit from the expertise of a leading supplier of rolling and plain bearings.

Mounting and dismounting

The Schaeffler Industrial Service experts offer mounting and dismounting services for rolling bearings that are applicable across industrial sectors. They have detailed knowledge and extensive experience in all industrial sectors.

The experts in the Industrial Service function are trained and skilled personnel who can provide reliable, rapid and competent assistance. The services are provided worldwide, either on site at your location or in Schaeffler workshop facilities.

Mounting and dismounting services

The mounting and dismounting services, *Figure 1*, page 125, include:

- mounting and dismounting of rolling bearings, plain bearings and bearing systems of all types by experts available worldwide
- instruction in the use of mounting tools
- installation of lubricators
- measurement and condition analysis of bearing arrangements
- problem solving and preparation of concept solutions
- design and manufacture of special tools
- rental of tools (only available in Europe)
- emergency service
- training courses on products and mounting
- certification of mounting and dismounting processes.

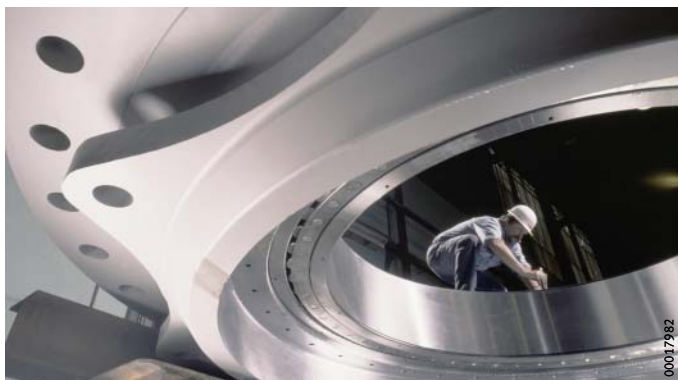

Figure 1
Mounting service

Advantages

The mounting services give the following advantages:

- readily available service worldwide
- correct mounting or dismounting through precise preparation
- professional mounting and dismounting using special high-quality tools
- increased plant availability and productivity as a result of reduced unplanned downtime
- correct use of bearings of all types as a result of customer training
- minimum time outlay by means of training on site.

Rental of tools

European customers who require special mounting and dismounting tools or measuring equipment only infrequently can rent these from Schaeffler on a weekly basis.

Our service includes:

- rapid delivery to the installation site
- rental costs including shipment costs
- checked quality products in keeping with the latest technological developments
- delivery of the tools, including all add-on parts
- user manuals available in several languages.

If one of our qualified experts in the Industrial Service function is commissioned to carry out the particular activity, rental costs are not generally incurred.



Services

Qualification Mounting errors are the cause of approximately 25% of all premature bearing failures. In addition to basic knowledge of rolling bearings, it is particularly important to have theoretical and practical knowledge of the correct mounting and dismounting procedures in order to achieve a long bearing operating life.

In order to ensure that the training received by mounting personnel is as close to reality as possible, Schaeffler offers individual training on mounting and dismounting processes.

Here, information on handling rolling bearings correctly and avoiding errors during mounting and dismounting is imparted by Schaeffler experts. This is carried out with direct reference to the specific application and the individual circumstances of the customer. A practical demonstration of the mounting and dismounting process is then provided, which also covers adherence to the necessary processes and specifications.

Finally, the training participants must put their acquired knowledge to the test. Only then do they receive application-specific certification from Schaeffler.

Further information

■ Enquiries:
mounting-services@schaeffler.com.

Lubrication In more than half of all cases, inadequate lubrication is the cause of unplanned machine downtime. The life of rotating machine elements can be significantly extended by the use of greases appropriate to the different operating and environmental conditions as well as the definition of and adherence to lubrication intervals and quantities.

- Services Services relating to lubrication, *Figure 2*, include:
- selection of lubricants and lubrication systems
 - mounting and commissioning of lubricators and lubrication systems CONCEPT
 - preparation of lubrication and maintenance plans
 - lubrication point management
 - consultancy on lubricants
 - lubricant investigations and tests.

- Advantages The Schaeffler lubrication service helps to:
- prevent failures of rotating components
 - increase productivity
 - reduce lubrication costs.

An extensive selection of high quality Arcanol rolling bearing greases is available, *Figure 2*. These greases were specially tested and selected for use in rolling bearings.



Figure 2
Supporting the lubrication service:
the large grease selection

Services

- Condition Monitoring** The malfunction-free and optimised operation of complex machinery and plant can only be achieved by means of condition-based maintenance. Schaeffler uses various processes for this purpose.
- Vibration measurements** The measurement of vibrations is a proven method here. Vibrations reveal damage in machinery at a very early stage. The vibration expert can assess the condition of the machine without the need for any dismantling work. A large proportion of possible causes of damage can thus be detected and assessed with little work. As a result, damaged components can be replaced as part of planned downtime. Depending on the type of machine and its importance for the production process, condition monitoring can be carried out by means of either continuous (online) monitoring or monitoring at regular intervals (offline).
- Continuous monitoring** For production-critical machinery, continuous monitoring, *Figure 3*, page 129, by means of vibration diagnosis is indispensable in many cases. Investment in such monitoring systems often pays for itself after a few months due to the reduced failure costs. Depending on the area of application, Schaeffler offers a wide range of solutions, including single channel standalone solutions for smaller equipment and medium-sized systems with up to 16 channels that can be extended on a modular basis. In addition to giving advice on selecting the right system, Schaeffler also implements monitoring of the machine. This includes not only hardware selection but also system configuration and, where necessary, its integration into existing systems. Schaeffler prepares condition reports at regular intervals defined in agreement with the customer. If any anomalies are found, a recommendation for action is issued. The customer can decide whether to carry out plant monitoring himself or to enlist the services of Schaeffler for online monitoring. Due to the communication options of the monitoring systems, remote analysis can be carried out by the Schaeffler experts.

Figure 3
Continuous monitoring



Regular monitoring

The failure of so-called “B” or “C” category plant items does not lead directly to downtime and does not therefore lead to expensive secondary damage. In the case of such machine parts, regular monitoring is generally recommended as a more economical option. The Schaeffler experts can assist in identifying the most economically appropriate solution between cost-effective continuous monitoring and regular monitoring.

In this type of monitoring, machinery is examined and assessed by vibration analysis at regular intervals, for example every four weeks. This regularity gives more in-depth knowledge of the normal condition of the machine. Deviations can thus be detected. For the monitoring concept, the selection of measurement points and monitoring accessories as well as the measurement interval play a decisive role. If deviations occur during measurement or if trends are to be investigated, the data can be sent to the Schaeffler Diagnosis Centre. Vibration experts will then analyse the data and prepare a diagnosis report. Through working with the Schaeffler experts, customers can build up their own know-how in analysis.

If no personnel are available for data logging, Schaeffler can also offer support in data logging. Experts from Schaeffler then carry out regular measurements on site.



Services

Troubleshooting Where malfunctions occur on a machine, defects and weaknesses must be detected and rectified very quickly. Based on many years of experience with different sectors and applications, the Schaeffler diagnosis experts are well versed in such troubleshooting tasks. Various types of information are fed into the analysis. These include earlier measurement records or repair reports. If no measurement records are available, the diagnosis experts orient themselves to the specific task through observation, perusing the machine documentation and holding discussions with the machine operators.

Problems or malfunctions in machine operation often become apparent through changes in vibration behaviour, unusual temperature patterns or similar phenomena. Where the diagnosis experts carry out measurements on the machine themselves, the measurement method is selected as a function of the specific machine and the type of malfunction. The Schaeffler diagnosis experts are familiar with all analytical techniques, from vibration measurement to torque analysis or endoscopy. As a result, they can quickly identify malfunctions and prepare proposed solutions. The investigation is closed out by a handover discussion between the diagnosis experts and all relevant employees on site. In addition to the results of the investigation, the recommended countermeasures are discussed in particular. These results are then documented with the recommendations in a measurement report.

Modal analysis Modal analysis is a particular form of vibration diagnosis. This method does not examine individual components of a machine but the machine as a whole. The aim is to determine the overall vibration behaviour of the machine. A model of the machine is created on the computer and a large number of measurement points are defined. The machine is then specifically excited to vibration using an impulse hammer. Based on parallel measurement of the excitation and resulting machine vibrations at the various measurement points, a vibration model of the machine can be determined by the computer and presented in three dimensions.

Modal analysis has a wide variety of possible applications:

- Determination of natural frequencies or resonance frequencies:
 - Due to design-related factors such as mass and rigidity, each machine has one or more natural frequencies. If the speed of the motor in a machine is within the range of a natural frequency, extreme vibrations may occur in the machine. With the aid of modal analysis, the Schaeffler vibration experts can submit recommendations for design improvements to the machine.
- Detection of the “soft spot” in a machine:
 - If high levels of vibration occur during commissioning or after a technical modification of a machine, this may be due to a so-called “soft spot”. This is defined as a rigidity problem, often caused by a poor quality connection between two machine parts, for example at a screw connection. For analysis, the measurements are used to produce an animation showing the movements of the machine. Showing the movement of the individual machine parts in relation to each other quickly leads to the “soft spot” in the machine. A joint discussion can be held to prepare proposals for improving the design of the machine.



Services

Endoscopy Digital, optical endoscopes can be used to examine the interior of a machine, *Figure 4*, to determine the extent of damage. The images can be stored as a digital photograph or video and form the basis of diagnosis by Schaeffler experts. The condition of individual components such as rolling bearings and gear teeth can be assessed. If the bearings inspected are Schaeffler products, the customer also has access to the knowledge of the Schaeffler application engineers. These experts will prepare a detailed damage analysis and submit proposals for improvement.



Figure 4
Endoscopy

Thermography Thermography is one of the most important non-destructive diagnostic techniques, *Figure 5*. Many technical problems manifest themselves in the form of heat generation, which can be detected with the aid of a high resolution infrared camera. The major advantage of thermography is the rapid, non-contact collection of temperature data. If a photograph is taken at the same time, the temperature patterns present in a machine part can be assigned on site.

Thermography can be used for assessment in relation to numerous objects, such as in the case of:

- non-contact monitoring of rolling bearings during operation
- thermal monitoring of processes.



Figure 5
Thermography® FLIR systems
Approval inspection of new plant

The combination of different diagnostic techniques enables the Schaeffler experts to carry out assessment of new plant irrespective of the manufacturer. Frequently occurring installation defects can thus be detected in the initial operation phase. These defects can include: misalignment of motors, pumps or fans as well as incorrect electrical connections in switch cabinets. The Schaeffler experts check the most common problems and record the actual status. Where necessary, corrective measures can then be requested from the plant manufacturer or operator in good time. If such defects remain undetected over the period of the warranty, their removal and the secondary damage may incur considerable costs and downtime.

Further information

- Enquiries:
industrial-services@schaeffler.com, +49 2407 9149-66.



Services

Tools and measuring devices

High-quality tools and measuring devices facilitate high quality of work. Our tools and measuring devices can be repaired in many cases. Regular maintenance and calibration leads to an extended service life and ensures good measurement results.

Repair

If damage occurs, the Schaeffler Repair Service offers rapid and reliable assistance.

The advantages include:

- repair by qualified skilled personnel
- use of original replacement parts
- safety inspection after any repair.

Maintenance and calibration

A mounting defect will often cause a major reduction in service life. If measuring devices are used in the mounting of rolling bearings, the service life of the bearing is directly dependent on the measurement accuracy.

Sensitive measuring devices such as enveloping circle gauges or alignment devices, as well as some tools, must undergo maintenance and calibration at certain intervals. This ensures consistently high quality of operating equipment and also extends the service life. The devices are checked by service experts from Schaeffler, repaired where necessary, subjected to maintenance and then recalibrated. Their suitability for problem-free use is confirmed by means of a certificate. Where necessary and if available, a suitable loan device can be provided.

Further information

- Enquiries:
repair-services@schaeffler.com.

Corrective maintenance

Once a machine problem has been diagnosed, it should be eliminated as quickly as possible. Two of the most frequent problems, namely unbalance in pumps and fans as well as misalignment of machine components to each other, can be corrected directly by the Schaeffler experts.

Balancing

Unbalance is one of the most frequent defects that lead to unexpected failure of rotating machine elements. Correct balancing gives a decisive increase in the life of rotating machine parts. This increases the productivity and availability of the machine. The Schaeffler experts reduce to a normal level any unbalance that occurs, for example, as a result of contamination, wear and repairs. They can detect and eliminate the causes on machinery operating at a speed of 40 min^{-1} to $10\,000 \text{ min}^{-1}$. Typical examples of such machines include pumps, ventilators, compressors, turbines and motors. Schaeffler offers not only a detailed analysis of the causes of the problem but also the elimination of unbalance.

Alignment

Many machines consist of different components, such as electric motors and pumps. After installation, repair or overhaul, the components of such machines must be aligned with each other, *Figure 6*. If this is carried out incorrectly or not at all, this results in high loads being placed on the bearings as well as increased energy demand and wear.

In addition to laser alignment systems, Schaeffler offers alignment of machinery as a service. Where necessary, the service technician from Schaeffler will take the necessary laser alignment system to the customer and carry out alignment of the machine in accordance with the manufacturer's specifications. The work is then documented.



Figure 6
Alignment

Further information

■ Enquiries:
industrial-services@schaeffler.com, +49 2407 9149-66.



Services

Rolling bearing reconditioning

It is often the case that new rolling bearings are fitted although the existing bearings could be restored to as-new condition by means of appropriate reconditioning. In many cases, reconditioning of rolling bearings is significantly more cost-effective than using new bearings, *Figure 7*.

- ① Before reconditioning
- ② After reconditioning



Figure 7
Rolling bearing raceway and rollers
before and after reconditioning

Advantages

Reconditioning is carried out irrespective of manufacturer and is thus not restricted to products from Schaeffler Technologies. Before reconditioning, the condition of the bearings can be assessed on site in consultation with experts from the Global Technology Network.

The advantages for the customer are:

- reductions in life cycle costs (LCC = Life Cycle Costs)
- increases in operating life
- savings in material and energy costs
- reductions in inventory costs
- high flexibility through short lead times
- feedback on the characteristics and frequencies of damage.

Quality

Schaeffler performs reconditioning of rolling bearings to uniform standards throughout the world. All sites apply identical processes and guidelines. Schaeffler rolling bearings are processed in accordance with the original drawings. In the case of all bearings, work is carried out using only original components and original replacement parts. High quality reconditioning is achieved as a result of our comprehensive knowledge of rolling bearings.

- Market sectors** Reconditioning of rolling bearings is of particular interest if these are used in machinery or vehicles in the following market sectors:
- raw material extraction and processing
 - metal extraction and processing
 - pulp and paper
 - railways.
- Dimensions** Reconditioning and, where required, modification can be carried out on rolling bearings with an outside diameter D of 100 mm to 4 500 mm. Please contact us for information on reconditioning or modifying bearings with other outside diameters.
- Overview** The operations necessary in reconditioning are dependent on the condition of the rolling bearing. In order to allow a reliable statement of the work required, the rolling bearing must be disassembled, cleaned and then carefully examined.
- Beyond this requalifying process (Level I), which is always necessary, further reconditioning steps may be appropriate, *Figure 8*.

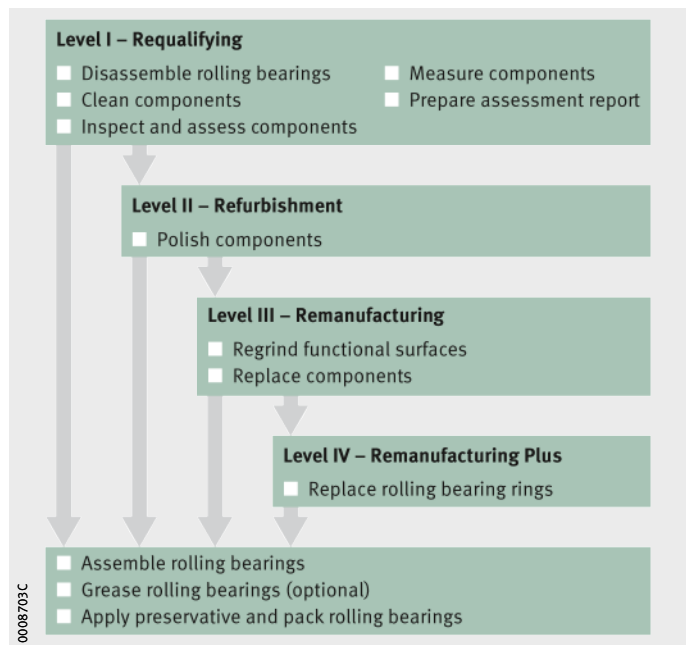

Figure 8
Level I to Level IV



Services

Worldwide reconditioning

Schaeffler offers the reconditioning of rolling bearings at several locations worldwide, *Figure 9*.



Figure 9
Reconditioning locations

Addresses

Europe	China
<p>Schaeffler Technologies AG & Co. KG</p> <ul style="list-style-type: none"> Georg-Schäfer-Straße 30 97421 Schweinfurt¹⁾ Tel. +(49) 9721 91-1919 reconditioning@schaeffler.com Mettmanner Straße 79 42115 Wuppertal²⁾ Tel. +(49) 202 293-2226 reconditioning@schaeffler.com <p>Schaeffler Manufacturing Rus OOO</p> <ul style="list-style-type: none"> 44-th Enzhenerny proezd, 11 432072 Ulyanovsk Tel. +(7) 84 2227 3325 kokorina@schaeffler.com 	<p>Schaeffler (China) Co., Ltd. (Taicang) Schaeffler Trading (Shanghai) Co., Ltd.</p> <ul style="list-style-type: none"> No. 1 Antuo Road, Anting, Jiading District 201804 Shanghai Tel. +(86) 21 3957 6500 reconditioning@schaeffler.com <p>Schaeffler (Ningxia) Co., Ltd.</p> <ul style="list-style-type: none"> Wenchang South Road 86 Xixia District 750021 Yinchuan Tel. +(86) 95 1207 2333 reconditioning@schaeffler.com
USA, Canada	Australia
<p>Schaeffler Group USA Inc.</p> <ul style="list-style-type: none"> 308 Springhill Farm Road Fort Mill, SC 29715 Tel. +(1) 888 462-8227 reconditioning@schaeffler.com 	<p>Bearing Engineering Services (BES) (A Division of Schaeffler Australia Pty Ltd)</p> <ul style="list-style-type: none"> 10 Melissa Street, Auburn, Sydney, NSW 2144 Tel. +(61) 2 87 17 81 11 BES.au@schaeffler.com www.schaeffler.com.au/bes

¹⁾ Reconditioning for bearings with $D \leq 500$ mm.

²⁾ Reconditioning for bearings with $D > 500$ mm.

Further information

- TPI 207, Reconditioning and Repair of Rolling Bearings.

Technical consultancy

Companies that wish to change to the concept of condition-based maintenance are supported by Schaeffler with training, attendance during the introductory phase, ongoing advice during the period of use and service contracts.

Condition-oriented maintenance

In condition-oriented maintenance, machinery and plant no longer undergo maintenance work on the basis of failures or times but on their assessed condition. In partnership with the customer, the advisory experts of Schaeffler prepare plans that give recommendations for action on the basis of the results of condition monitoring. These recommendations result in targeted maintenance measures and thus to reduced costs.

Service concepts for plant manufacturers and operators

Services are not “off the peg” products and the requirements vary according to the machine and the knowledge on site. Due to the wide portfolio of Schaeffler services, local certified Schaeffler employees can weave together the right package of Schaeffler training and services together with in-house activities. The scope is enormous and dependent on the prior knowledge and usable work capability as well as the requirements for quality of monitoring.

The following four examples show the extent of the scope and how widely service concepts can vary. Starting from the customer requirements, the Schaeffler experts prepare a concept to meet the needs and assist in its implementation.

Example 1: Instruction

Company A has employees with experience in the field of condition diagnosis.

In this case, it is sufficient to instruct the employees of the company in the use of the systems and accompany them while making the initial steps. In difficult cases, assistance can be requested from the Schaeffler experts. These will help in the analysis and formulation of measures.



Services

Example 2: Teaching Company B would like to build up its own knowledge in the field of condition diagnosis.
Condition diagnosis is a complex subject. Building up knowledge therefore takes time. In such cases, Schaeffler offers a two-year programme, after which even customers without prior knowledge can themselves monitor the condition of their machinery. The support given by the Schaeffler experts is progressively reduced in stages and the customer's employees use their new knowledge directly in their daily work.

Example 3: Outsourcing Company C would like to completely outsource the area of condition diagnosis.
Schaeffler offers complete packages under which the entire service is provided by Schaeffler. This begins with the initial operation of systems and progresses through continuous monitoring to complete leasing of the hardware, such that no initial costs are incurred by the customer. Such monitoring packages are very attractive, for example, to operators of wind turbines.

Example 4: Offering a service Company D is a plant manufacturer and would like to offer condition monitoring as a service itself.
In this case, Schaeffler acts as a subcontractor for the mostly portable monitoring systems, as a trainer to the service employees of the plant manufacturer and as an expert team. The expert team always moves into action when machines show sets of characteristics that cannot be clearly assessed by the employees of the plant manufacturer. The plant manufacturer can thus offer its customers a highly qualified monitoring service without having to establish its own experts.

Further information

■ Enquiries:
industrial-services@schaeffler.com, +49 2407 9149-66.

TCO approach

The Schaeffler approach to reducing total costs (TCO, Total Cost of Ownership) is a practically based concept for plant operators (MRO) and plant manufacturers (OEM). The aim is to reduce operating costs associated with rolling bearings and increase plant availability on a continuing basis. The costs incurred are objectively and measurably compared with the benefits to be accrued by means of appropriate parameters.

In the case of MRO, Schaeffler works as a partner with employees from production and maintenance facilities to optimise and conserve the value of plant. With the user, Schaeffler identifies specifically named problems and submits technical approaches to solutions. Furthermore, Schaeffler provides proposals for cost reductions that are based on experience within specific sectors and spanning different sectors. This analysis covers plant components, operations and qualification measures as well as their practical implementation.

Schaeffler is also interested in advising OEMs on product design with favourable maintenance-related characteristics, in order to achieve a significant contribution to reductions in operating costs as early as the plant design phase.





FAG



Training courses

Training courses

	Page
Product overview	
Training courses	144
Features	
Target groups	145
Basic training on rolling bearings, plain bearings and linear guidance systems	145
Rolling bearing theory	145
Workshops on applications	145
Conditioning monitoring by means of vibration analysis	146
Mounting and dismounting	146
Vibration analysis and measuring systems	146
Teachers and trainers	146
Training locations	147
Quality assurance	147
Training courses, standard and individual	148
Training material	149



Product overview Training courses

Rolling bearing technology Training example

TRAINING-BEARING-BASIC-TECH-2



0004333B

Mounting of rolling bearings Training example

TRAINING-BEARING-MOUNTING-PRACT



0004334D

Machinery monitoring Training example

TRAINING-CM-D3-BASIC



0004335F

Training courses

Features Appreciating the use of rolling bearings, linear guidance systems and plain bearings as indispensable elements in thousands of applications requires the necessary understanding of these machine elements. Schaeffler Technologies offers numerous theory and practical training courses for its extensive product portfolio. Starting from product knowledge, it is possible to become familiar with subject areas such as mounting and dismounting of rolling bearings using the optimum tools and the condition monitoring of bearing arrangements, especially through the use of noise, vibration and torque measurements.

Systematic learning processes, in conjunction with the appropriate methods, help the training participant to discover the world of bearing arrangements. With the support of machine building engineers and technicians who have undergone didactic and methodological training, there is no longer any obstacle to effective learning progress.

Target groups Our training courses cover the information needs of employees in a very wide variety of areas of activity within a company. In this way, the technically oriented employee, whether a designer, fitter or maintenance person can find the right training course, in the same way as the employee in business administration, for example in purchasing.

Basic training on rolling bearings, plain bearings and linear guidance systems All target groups are considered using a uniform training approach. In general, the initial steps are provided by basic training covering the different characteristics, features and types of rolling bearings, plain bearings and linear guidance systems as well as their combination to form systems, extending all the way to mechatronic units. Application examples reflect the selection criteria and the customer benefits achieved.

Rolling bearing theory These product-oriented training courses are followed by modules covering rolling bearing theory as well as selected applications. Rolling bearing theory conveys the necessary knowledge on subjects such as bearing clearance, load distribution in the bearing, rating life and lubrication.

Workshops on applications In workshops, the participants consider applications from practice, such as the bearing arrangements in a machine tool or a shaft bearing arrangement. All process steps are covered, from bearing selection and bearing calculation through to mounting. We also offer workshops in the field of mechatronics (principles and products).



Training courses

Conditioning monitoring by means of vibration analysis

Furthermore, we offer a certification training course with examination in accordance with DIN ISO 18436-2. Knowledge of condition monitoring by means of vibration analysis is certified by an independent body that is accredited by the DAkkS. This certificate is recognised at an international level.

Mounting and dismounting

Numerous training modules cover the mounting and dismounting of rolling bearings and linear guidance systems. Based on perception and exercises, the participant gains the mounting knowledge and skills that he will require in practice. Our training courses on mounting cover a large number of applications. Mounting exercises on individual products are followed by work on more complex systems such as gearboxes or wheelsets.

Vibration analysis and measuring systems

The possibilities for plannable and economical design of maintenance work on machines, plant and rolling bearings are communicated to the training participant in appropriate courses. Our trainers communicate the theoretical principles of vibration analysis, the practical use of measurement systems and the handling of configuration and analysis software. The theoretical knowledge acquired is consolidated by means of practical exercises.

Teachers and trainers

For the further training of teachers and trainers, Schaeffler Technologies offers a basic course and an advanced course each once per year. The three-day basic course includes product training and the principles of rating life calculation. A one-day mounting training course can be booked to follow on directly. The three-day advanced course covers the rolling bearing design of a gearbox shaft according to the catalogue and Schaeffler calculation software such as *medias* interchange and BEARINX-online.

Training locations Schaeffler has its own training centres worldwide. Qualified presenters with considerable experience ensure practice-oriented knowledge transfer in various languages at local sites. Alternatively, we will be pleased to train your employees at your location.

Training centres worldwide The Schaeffler Technology Centers – Training (training centres with headquarters in Eltmann, Germany) offer theoretical and practical training courses in their modern training facilities. All product and services portfolios of Schaeffler Technologies are covered in detail. Starting from the principles and progressing to more detailed special knowledge, training courses communicate knowledge of rolling bearing theory, mounting and dismounting as well as all levels of condition monitoring and mechatronics.

Quality assurance Through continuous market monitoring and exchange of experience, Schaeffler is in a position to continuously improve its training courses. What is particularly important to us is the ideas and suggestions that we receive through feedback from our training participants. Certification of the Schaeffler Technical Training Centres in accordance with ISO 9001:2008 underlines our continuous aspiration to increasing quality. After training, each training course attendee receives a certificate.



Training courses

Training courses, standard and individual

The standard programme of training courses is sufficient in most cases to achieve acquisition of the knowledge necessary for day-to-day work. Upon customer request, Schaeffler also offers individually tailored training courses. In these cases, customers can themselves define the key components of the content. The standard training programme for the areas of rolling bearing technology and mounting as well as condition monitoring is already comprehensive; an excerpt is shown in the table.

Excerpt from the Schaeffler training portfolio

Training courses	
Rolling bearing technology and mounting	Basic training: Rolling bearing technology
	Mounting of rotary bearings
	Basic training: Mounting of rolling bearings (in gearboxes)
	Practical training: Mounting of rolling bearings (using large rolling bearings)
	Linear – Products and applications
	Mounting of linear bearings
	Rolling bearing failures: Identifying causes – Optimising operation
	Mounting and maintenance of rolling bearings for rail vehicle maintenance personnel (customer location)
	Maintenance of spindle bearings
Condition Monitoring	Detector III: Entry level, design, machine diagnosis, balancing
	SmartCheck: Introduction, design
	Vibration condition monitoring Category 1 and 2 in accordance with DIN ISO 18436-2 with certification
	DTECT X1 _s
	ProCheck
	Administrator 4
Mechatronics	Basic training: Mechatronics
Special training	Training completely oriented to the application

Training material

Literature on the correct mounting of bearings is readily available, however there is a general lack of appropriate equipment on which apprentices can practise in as practical a sense as possible. As a result, trainers from the Schaeffler training workshops have developed a mounting cabinet and a mounting cross for practising the mounting and dismounting of rolling bearings.

Mounting cabinet

The mounting cabinet is used in the basic course. The aim of this rolling bearing course is to communicate knowledge on the selection of the correct bearing, correct mounting and dismounting and the maintenance of bearing positions. Material from the mounting cabinet is, however, also used to provide instruction on individual contents with the aid of various mounting sets, *Figure 1*.



Figure 1
Basic course:
Mounting cabinet

Mounting cross

In order to provide professional training courses on the correct mounting and dismounting of rolling bearings, Schaeffler has developed the so-called mounting cross, *Figure 2*. This piece of equipment allows the expert to communicate the correct handling procedure visually, using a variety of different bearings, and under realistic conditions.



Figure 2
Mounting cross

Further information on the Internet

- www.schaeffler.de, in menu item Products & Services ➔ INA/FAG Products ➔ Training courses
- Enquiries: schulungszentrum@schaeffler.com.



Ordering designation	Title
Mounting	
FAG	Flyer: FAG Heating Devices
FIM	Flyer: FAG Induction Units with Medium Frequency Technology
TPI 156	Tapered Roller Bearing Units TAROL – Mounting, Maintenance, Repair
TPI 180	FAG Tools for Thermal Dismounting
TPI 195	FAG Pressure Generation Devices
TPI 196	FAG Hydraulic Nuts
TPI 200	FAG Heating Devices for Mounting of Rolling Bearings
TPI 216	Tools for Mechanical Mounting and Dismounting of Rolling Bearings
TPI 217	Induction Units with Medium Frequency Technology
MH 1	Mounting Handbook – Mounting of Rotary Bearings
WL 80 112	Mounting and Dismounting of Rolling Bearings (Tools, Devices, Methods)
Lubrication	
OFC	Flyer: FAG CONCEPT2
OFG	Flyer: FAG CONCEPT Precision Grease
OFO	Flyer: FAG CONCEPT Precision Oil
TPI 168	Rolling Bearing Greases Arcanol
TPI 176	Lubrication of Rolling Bearings
TPI 252	Automatic Relubrication Devices
WL 80382	Flyer: FAG CONCEPT8
Training	
WL 80 386	Certified Vibration Expert to DIN ISO 18436-2

Ordering designation	Title
Condition Monitoring	
FQB	Flyer: FAG SmartQB
SI SK001	Flyer: FAG SmartCheck Service Kit
TPI 170	FAG DTECT X1 _s – Continuous Monitoring of Machinery and Equipment
TPI 182	FAG Alignment Tools – Top-Laser: SMARTY2 · TRUMMY2 · EQUILIGN · SHIM
TPI 214	FAG SmartCheck
TPI 216	Tools for Mechanical Mounting and Dismounting of Rolling Bearings
TPI 217	Induction Units with Medium Frequency Technology
TPI 234	Condition Monitoring of Greases in Rolling Bearings
TPI 252	Automatic Relubrication Devices
TPI WL 80-64	FAG Detector III – The Solution for Monitoring and Balancing
TPI WL 80-69	FAG ProCheck – State of the Art Machinery Monitoring for Maximum Availability
WL 80 362	Flyer: FAG ProCheck
WL 80 366	Flyer: FAG Wear Debris Check
WL 80 373	Flyer: FAG WiPro _s
WL 80 375	Flyer: FAG SmartCheck Starter Kit
WL 80 378	Flyer: FAG Top-Laser EQUILIGN
WL 80 380	Flyer: FAG GreaseCheck
Rolling Bearing Reconditioning	
TPI 207	Reconditioning and Repair of Rolling Bearings



Addresses

Germany Schaeffler Technologies AG & Co. KG
Postfach 1260
97419 Schweinfurt
Georg-Schäfer-Straße 30
97421 Schweinfurt
Tel. +49 2407 9149-66
Fax +49 2407 9149-59
industrial-services@schaeffler.com
www.schaeffler.com/services

Schaeffler Technologies AG & Co. KG
Industriestraße 1–3
91074 Herzogenaurach
Tel. +49 91 32 82-0
Fax +49 91 32 82-49 50
info.de@schaeffler.com

Schaeffler Technologies AG & Co. KG
Industriestraße 2
97483 Eltmann
Tel. +49 9522 71-503
Fax +49 9522 71-511
schulungszentrum@schaeffler.com

Worldwide You can find all the addresses and
contacts for Schaeffler at
www.schaeffler.com



Schaeffler Technologies AG & Co. KG

Postfach 1260

97419 Schweinfurt

Georg-Schäfer-Straße 30

97421 Schweinfurt

Germany

Internet www.schaeffler.com/services

E-mail industrial-services@schaeffler.com

Phone +49 2407 9149-66

Fax +49 2407 9149-59