

FAG



Induction Units with Medium Frequency Technology

SCHAEFFLER

Foreword

Induction units with medium frequency technology are an innovative solution for the heating of large and heavy workpieces. They are suitable for thermal mounting and dismantling – in contrast to the heating devices of the series HEATER, which represent an economical solution for thermal mounting only. Due to continually increasing requirements and increasingly complex applications, conventional methods are being pushed increasingly to their limits. With induction heating by means of medium frequency technology, these requirements can be fulfilled while achieving high levels of energy efficiency, safety and flexibility.

In thermal mounting, a workpiece such as a rolling bearing or a gear is heated and as a result undergoes expansion. While still warm, it is slid onto its seat, where a press fit is created after cooling. In thermal dismantling, speed is also an essential requirement. This is because, in order to loosen the press fit, only the workpiece to be dismantled must be heated, while the seat itself must remain cold. This requires very rapid input of energy into the workpiece.

In medium frequency technology, a frequency inverter (generator) is installed between the induction coil (inductor) and the mains connection. This generator feeds the inductor at a frequency of approx. 10 kHz to 25 kHz. Due to the high frequency, the inductor can be of a significantly more compact design, while maintaining the same induced power loss, than in induction units with mains frequency technology. Heating occurs, due to the skin effect, only in the surface of the workpiece and the penetration depth is only a few tenths of a millimetre. The workpiece is heated through as a result of the heat flow occurring. The shrink fitted component is heated at a significantly faster rate than the shaft, which means that joint clearance is created for a certain period and the shrink fit connection can be loosened.

This publication describes the latest generation of generators with digital control. In the case of the inductors, it is possible to select from different designs depending on the application. Flexible inductors offer the capability of adapting to components of different size and geometry. Rigid inductors are more suitable for batch production where the emphasis is less on flexibility and more on short set-up times and high process reliability.

The application examples show various possibilities for using the induction unit. We would be pleased to advise you on the configuration of an induction unit for your applications.

Contents

	Page
Technical principles	Induction heating 4
	Functional principle 4
	Advantages..... 5
	Suitability for rolling bearings 5
	Induction units with medium frequency technology 6
	Main components 6
	Advantages..... 7
	Areas of application 8
	Configuration..... 8
	Internal and external field inductors..... 9
	Internal field inductors..... 9
	External field inductors 9
	Safety guidelines..... 10
Electromagnetic field 10	
Generators	Characteristics 11
	Expanded functional scope..... 12
	Operating modes..... 13
	Reduction in residual magnetism 14
	Designs 15
	Scope of delivery 17
	Accessories 18
	Temperature sensor 18
	Potential equalisation cable..... 18
	Inductor feed cable 19
Signal tower..... 20	

	Page
Inductors	
Types.....	21
Flexible inductors.....	21
Rigid inductors.....	23
Accessories	24
Magnetic holder.....	24
Tensioning belt with aluminium holder	24
Heat protection cover	25
Tools for mounting	
Transport and mounting tool	26
Services	
Extensive service portfolio	28
Mounting and dismounting services.....	28
Other services.....	29
Application examples	
Dismounting of inner rings	32
Batch mounting of bearings in housing	34
Batch mounting of large spherical roller bearings	36
Batch dismounting of labyrinth and inner rings.....	38
Appendix	
Information required for preparation of proposal	43

Induction heating

Functional principle

Induction heating is a direct heating method that can be used to heat all electrically conductive materials. If an alternating voltage is created at an inductor, this creates a strong alternating magnetic field. If a bearing ring is placed within this alternating field, a voltage is induced in the ring. A high short circuit current is created that heats the ring, *Figure 1*.

In induction heating, the penetration depth is dependent on the frequency of the alternating current. During induction heating, the bearings become magnetic. The reduction required in residual magnetism after the heating operation is automatically carried out using the same inductor.

- ① Short circuit current I_R in bearing ring
- ② Alternating magnetic field
- ③ Bearing ring
- ④ Exciter coil

Figure 1
Principle of induction heating

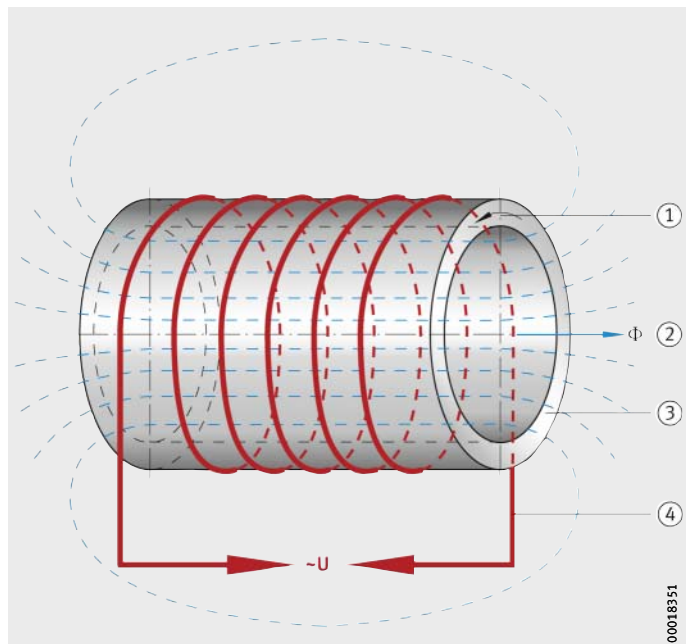

Advantages

The heat is generated directly by the medium frequency current, in other words without any contact between the inductor and the workpiece. Since the short circuit current in the bearing ring is present predominantly at the surface due to the skin effect and the good magnetic coupling, the surface of the ring is heated more rapidly than the interior of the ring. The heat is generated directly in the workpiece and does not require transfer from outside by means of radiation, conduction or convection. As a result, the heat loss in this method is significantly smaller and the power transferred is greater than in other heating methods.

This fact helps to address the requirement that, in the loosening of shrink fit connections, as little heat as possible should pass into the shaft, in order to create sufficient clearance between the inner ring and shaft. The rapid heating rate and the introduction of a defined, specific heat input into the workpieces are characteristics of induction heating.

Suitability for rolling bearings

Induction heating units are suitable for the dismantling of inner rings on cylindrical roller and needle roller bearings, labyrinth rings, couplings and other rotationally symmetrical parts with a bore of at least 60 mm. Where smaller press fits are present, however, the shaft is also heated so rapidly that the interference is no longer eliminated.

Induction heating units can be used to heat parts for both mounting and dismantling.

Induction units with medium frequency technology

Main components Induction units with medium frequency technology comprise a generator and inductor as the main components. Depending on the application, other accessories are necessary, such as an inductor feed cable or holding devices for flexible inductors.

Generator The generator contains a frequency inverter and supplies the inductor with an alternating voltage in the frequency range 10 kHz to 25 kHz. Furthermore, the complete controller for the induction unit is integrated in the generator.

The design of the generator is selected as a function of the power required and the mains voltage available at the point of use.

Inductor The inductor is the induction coil that is used to transfer the energy to the workpiece to be heated. Depending on the placement of the windings, a distinction is made between an internal and an external field inductor.

The design of the inductor can be a flexible inductor or rigid inductor. Rigid inductors are matched to the specific requirements of the application and are designed accordingly.

Advantages

Induction units with medium frequency technology from Schaeffler have the following advantages:

- The unit is smaller and lighter than comparable units using mains frequency technology and can therefore be used with greater mobility and flexibility.
- Versatile application is possible by means of flexible and rigid inductors.
- Temperature and time control as well as other operating modes facilitate convenient handling and prevent overheating of the workpiece.
- They have lower energy demand and higher performance due to high efficiency.
- They have an air-cooled system and thus require no cooling water.
- The generator runs almost free of noise, so there is no noise impact at the workstation.
- No problems with magnetised workpieces are experienced since there is a function for automatic reduction of residual magnetism after each heating operation.
- Uncomplicated connection to the electricity grid is possible by means of a 32-A or 63-A CEE plug. In contrast, conventional heating devices with mains frequency normally require at least 125 A and thus require costly stationary installation in the electricity grid.
- Inductors can be easily connected or replaced by means of connection via plug and coupling.

Induction units with medium frequency technology

Areas of application

Induction units with medium frequency technology are suitable for numerous applications, such as:

- heating of bearings for mounting and dismounting
- batch dismounting of bearing inner rings and labyrinth rings, for example in the case of wheelset bearings in rail vehicles
- dismounting of bearing inner rings from traction motors in rail vehicles
- heating of large components such as bearings or bearing seats in a machine support, for example bearings in wind turbines
- heating of roll rings and couplings, for example in steelworks
- loosening of shrink fit connections.

Configuration

The configuration of an induction unit is always dependent on the specific application and requires considerable experience. We will be pleased to assist you in the selection of suitable generators, inductors and accessory components. If necessary, rigid inductors specifically matched to the application can also be designed and produced.

The information required for the preparation of a proposal is compiled in a checklist, see page 43.

Internal and external field inductors

The inductor transmits the energy provided by the generator, with the aid of the alternating magnetic field, to the workpiece. Depending on the application and the mounting processes, the inductors are placed either externally around the workpiece (internal field inductor) or within the bore (external field inductor).

Internal field inductors

In the case of the internal field inductor, the workpiece is located within the windings of the inductor, *Figure 1*. This principle is applied, for example, in the mounting and dismounting of bearing inner rings. Depending on the application, the inductor can be of a rigid or flexible design.

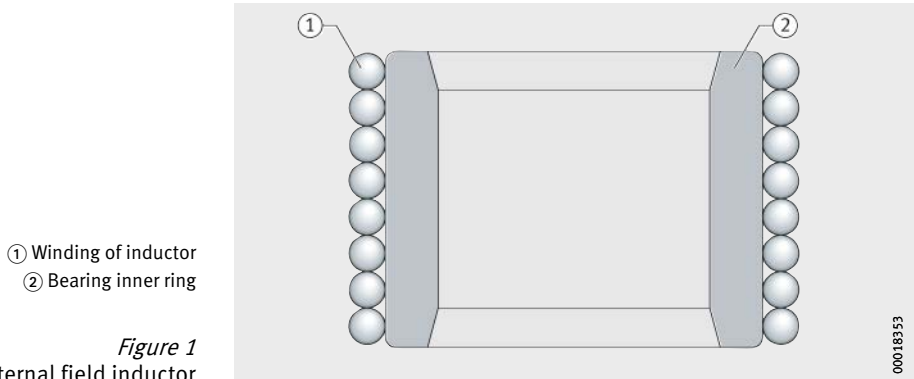

External field inductors

In the case of the external field inductor, the workpiece is located outside the windings of the inductor, *Figure 2*. This principle is applied, for example, in the mounting of bearings and for the heating of housings and machine supports. Depending on the application, the inductor can be of a rigid or flexible design.

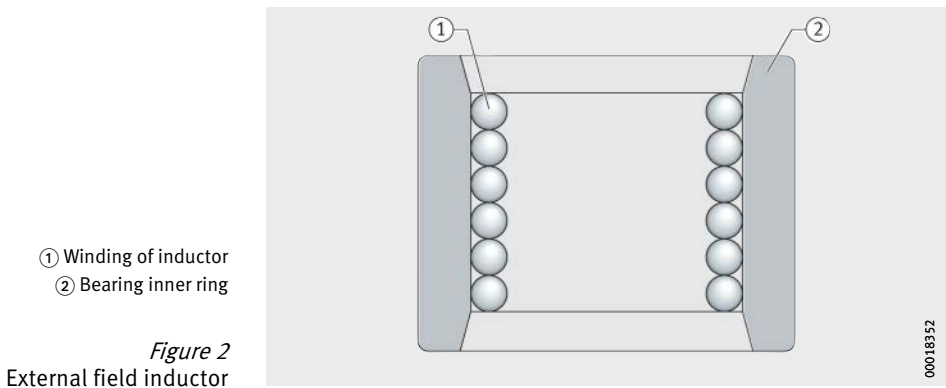

Safety guidelines

The design and production of induction units from Schaeffler is carried out in compliance with the directive 2014/35/EU. Due to the principle used, however, hazards can occur as a result of electromagnetic fields, electrical voltage and hot components.

Electromagnetic field

When the induction unit is operated, an alternating electromagnetic field is created in the vicinity of the inductor which heats workpieces made from electrically conductive material and can disrupt the function of electrical and electronic components.

As a result, there are risks of death and injury in the vicinity of the inductor for persons:

- with active medical aids such as pacemakers and similar devices
- with metallic implants
- with metallic objects in contact with the body such as watches, rings, chains, wristbands or keys.

Electronic objects such as mobile telephones, credit cards and other magnetic or electronic data carriers can be damaged in the operating area of the electromagnetic field.

Further information

In order to prevent the occurrence of personal injury or damage to property, the user manuals for the generator and inductor must be strictly observed:

- BA 43, HEAT-GENERATOR20-2, HEAT-GENERATOR40-2 – Generators for Induction Units with Medium Frequency Technology
- BA 44, HEAT-INDUCTOR..M-D15, HEAT-INDUCTOR..M – Flexible Inductors for Induction Units with Medium Frequency Technology
- User manuals for rigid inductors.

Generators

Characteristics

The generators HEAT-GENERATOR20-2 and HEAT-GENERATOR40-2 are the latest generation of generators for induction units from Schaeffler, *Figure 1*. The completely revised devices have a digital controller. This results in numerous new possibilities and expanded functions.

- ① HEAT-GENERATOR20-2
- ② HEAT-GENERATOR40-2

Figure 1
Generators



Fundamental characteristics

Characteristics of generators HEAT-GENERATOR20-2 and HEAT-GENERATOR40-2:

- effective power 20 kW or respectively 40 kW
- operating frequency 10 kHz to 25 kHz
- electrical efficiency of generator > 90%
- integrated function for reducing residual magnetism
- time and temperature control as well as other operating modes
- internal and external field inductor possible as a function of requirements
- flexible and rigid inductors possible as a function of requirements
- compact system, low mass
- simple connection or replacement of inductors by means of connection via plug and coupling
- air-cooled system.

Generators

Expanded functional scope

Control of the induction unit is carried out by the generator and is in a digital form. The operator unit of the generator is equipped with a 7 inch TFT touch display, *Figure 2*.

In addition to the numerous integrated operating modes, see page 13, the generator has the following functions:

- presentation of temperature patterns on the display
- storage and export of temperature patterns by means of an integrated temperature recorder
- separate registration for operator and commissioner, with different access rights
- optional function for delayed start of the heating operation after switching on, in order to allow withdrawal from the immediate environment of the inductor
- alarm functions for protection of the workpiece against overheating:
 - temperature increase alarm and temperature alarm on overshoot
- selection between different colour variants for interface presentation for matching to the light conditions in the environment
- display switchable between German and English
- display of technical data on the induction unit and the current heating operation
- for service, remote access possible via an Ethernet interface.

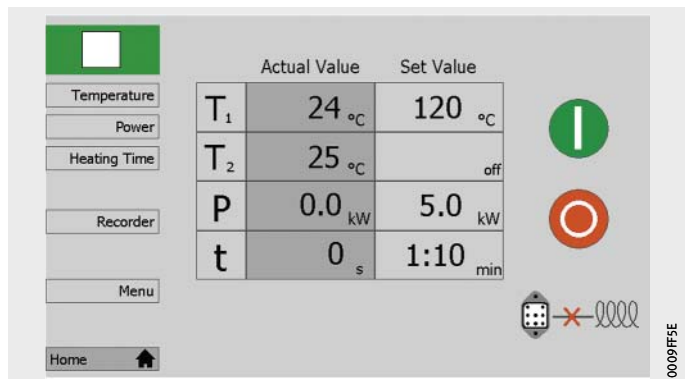

Figure 2
Operator unit of generator,
start page

Operating modes	Digital control of the generator leads to wide-ranging possibilities, including demanding heating operations. In addition to the classic operating modes such as time and temperature control, the generator offers other, more complex operating modes. These facilitate the use of induction heating in cases such as mounting conditions or component geometries that require precisely positioned and differentiated control of the heating operation.
Temperature control	<p>In temperature control, the workpiece is heated to the set temperature, after which temperature holding operation starts. The temperature regulation system, taking account of the set hysteresis, ensures that the workpiece is held at the nominal temperature. For measuring the temperature on the workpiece, 1 or 2 temperature sensors can be used.</p> <p>If 2 temperature sensors are used, regulation is always carried out by the temperature sensor that shows the higher temperature. This helps to prevent overheating of a workpiece if it is not known at which point on the workpiece the greatest heating occurs.</p>
Time control	In time control, the heating operation ends when the set heating time has expired. The heating time can be set to a precise number of seconds.
Combined operation	Temperature and time control can also be activated at the same time. In this combined operation, the heating operation ends when the set heating time has expired. If the nominal temperature is reached before the heating time has expired, temperature holding operation will start.
ΔT control	ΔT control facilitates the monitoring and control of temperature differences between two measurement points. The measurement points can also be located on different components. This means it is possible, for example in the heating of non-separable rolling bearings, to prevent the occurrence of unacceptably high preloads that can render the bearing unusable.
Ramp control	Ramp control facilitates multi-stage ramp functions with controlled temperature increase and temperature holding ranges.

Generators

Master/slave operation Master/slave operation facilitates the use of two generators communicating with each other via the Ethernet interface. This means it is possible, for example, to achieve controlled heating in different heating zones.

Inductor detection Inductor detection means that the generator can identify different rigid inductors as soon as they are connected to the generator. Operation is then carried out automatically using the heating program that is stored in the generator for the relevant inductor. In the heating program, all parameters of the heating operation such as power, nominal temperature and heating time are specified.

Reduction in residual magnetism The generator has an automatic function for reducing residual magnetism. As a result, the residual magnetism in the workpiece is reduced at the end of the heating operation to the level that was present before induction heating.

The reduction in residual magnetism is achieved by reducing the current strength within 10 milliseconds in a linear progression to 0 A, *Figure 3*.

I = current strength
t = time

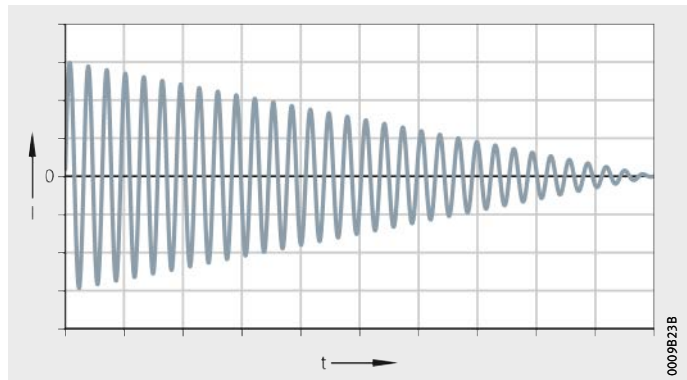

Figure 3
Reduction in current strength
at end of heating operation

Designs

The generators are available in two power stages with an effective power of 20 kW or respectively 40 kW. For each of these power stages, there is a design for connection to a voltage rating of 400 V and of 480 V.

The technical data as well as the connections and interfaces are compiled hereinafter, see tables, page 15 and page 16.

Technical data of generators with voltage rating of 400 V

Designation		Generator HEAT-GENERATOR	
		20-2	40-2
Cooling	–	Open circuit ventilation	
Mains voltage	V	3×380 – 3×440	
Mains frequency	Hz	50 – 60	
Voltage tolerance	–	±10%	
Mains current rating	A	31 ¹⁾	62 ¹⁾
Mains power	kVA	22 ¹⁾	43 ¹⁾
Connector plug CEE	A	32	63
Line-side fuse protection	A	32	63
Effective power	kW	20 ¹⁾	40 ¹⁾
Output voltage	V	450	700
Output current	A	170	210
Output frequency	kHz	10 – 25	
Length of mains connection cable	m	5	
Width	mm	277	365
Depth (with mains connection cable)	mm	610	
Height (with grips)	mm	540	695
Mass	kg	30	55
Ambient temperature	°C	0 – +40	
Storage temperature	°C	–5 – +55	
Relative humidity (operation)	–	5% – 80%, non-condensing	
(storage)	–	5% – 95%, non-condensing	
Protection type	–	IP21	
Noise emission under full load	dB (A)	69	82
Firmware	–	Update facility via USB	

¹⁾ Valid for voltage rating of 400 V.

Generators

Technical data of generators with voltage rating of 480 V

Designation		Generator HEAT-GENERATOR	
		20-2-480V	40-2-480V
Cooling	–	Open circuit ventilation	
Mains voltage	V	3×460 – 3×500	
Mains frequency	Hz	50 – 60	
Voltage tolerance	–	±10%	
Mains current rating	A	29 ¹⁾	56 ¹⁾
Mains power	kVA	24 ¹⁾	47 ¹⁾
Connector plug CEE	A	32	63
Line-side fuse protection	A	32	63
Effective power	kW	20 ¹⁾	40 ¹⁾
Output voltage	V	450	700
Output current	A	170	210
Output frequency	kHz	10 – 25	
Length of mains connection cable	m	5	
Width	mm	277	365
Depth (with mains connection cable)	mm	610	
Height (with grips)	mm	540	695
Mass	kg	30	55
Ambient temperature	°C	0 – +40	
Storage temperature	°C	–5 – +55	
Relative humidity (operation)	–	5% – 80%, non-condensing	
(storage)	–	5% – 95%, non-condensing	
Protection type	–	IP21	
Noise emission under full load	dB (A)	69	82
Firmware	–	Update facility via USB	

¹⁾ Valid for voltage rating of 480 V.

Connections and interfaces

Designation	Quantity	Generator HEAT-GENERATOR20-2, HEAT-GENERATOR40-2, HEAT-GENERATOR20-2-480V, HEAT-GENERATOR40-2-480V
Mains connection	1	■
Earth connection	1	■
Power connection	1 pair	■
Socket for type K thermocouple	2	■
USB connection	1	■
Connection for signal tower	1	■
Control connection for inductor	1	■
Ethernet connection	1	■
EtherCAT connection	1	■

■ Present

Scope of delivery

The scope of delivery of the generator, *Figure 4*, comprises:

- generator
- 2 temperature sensors with holding magnet
- potential equalisation cable with holding magnet
- user manual.

Accessories for optional ordering:

- signal tower
- inductor feed cable.

- ① Generator
- ② Temperature sensors
- ③ Potential equalisation cable
- ④ User manual

Figure 4
Scope of delivery of generator



Ordering designations

- HEAT-GENERATOR20-2**
- HEAT-GENERATOR20-2-480V**
- HEAT-GENERATOR40-2**
- HEAT-GENERATOR40-2-480V**

Generators

Accessories

This section describes the accessories that are included in the scope of delivery and the accessories that are available separately.

Temperature sensor

The temperature sensor HEAT-GENERATOR.SENSOR supplied with the generator is a type K thermocouple with a magnetic clamp, *Figure 5*.

The temperature sensor is designed for a maximum temperature of +200 °C. The magnetisation introduced by the magnet is $> 2 \text{ A/cm}$.



Figure 5
Temperature sensor
HEAT-GENERATOR.SENSOR

Ordering designation

HEAT-GENERATOR.SENSOR

Potential equalisation cable

The potential equalisation cable, *Figure 6*, supplied with the generator is used for the potential equalisation function. It is not a substitute for earthing. Earthing must never be carried out using a magnetic connection, only with a fixed connection such as a screw connection.

Potential equalisation function

In order to prevent falsification of temperature measurement on the workpiece to be heated, this must be connected using the potential equalisation cable supplied with the generator. The magnetisation introduced by the magnet is $> 2 \text{ A/cm}$.



Figure 6
Potential equalisation cable

Ordering designation

Available by agreement.

Inductor feed cable

The inductor feed cable HEAT-GENERATOR.CONNECT, *Figure 7*, is used for the power connection of a flexible inductor to the generator. The length of the inductor feed cable is 3 m.

The inductor feed cable has two single-pin round plug connectors for connection to the generator and the inductor. The round plug connectors are touch-safe and have a bayonet lock to prevent detachment.



Figure 7
Inductor feed cable
HEAT-GENERATOR.CONNECT

Data on inductor feed cable

Description	HEAT-GENERATOR.CONNECT
Number of cables	2
Length per cable	3 m
Cable diameter	25 mm
Mass per cable	5 kg
Connection	Round plug connector with bayonet lock

Ordering designation

HEAT-GENERATOR.CONNECT

Generators

Signal tower The signal tower HEAT-GENERATOR.LIGHTS, *Figure 8*, is available as an accessory and has the following equipment features:

- signal display of optical elements over 360°
- green signal lamp
- red signal lamp
- acoustic element.

The signal tower can give a visible display of the operating status of the generator at considerable distance and indicate malfunctions in the operation of the induction unit.



Figure 8
Signal tower
HEAT-GENERATOR.LIGHTS

Ordering designation

HEAT-GENERATOR.LIGHTS

Inductors

- Types** The inductor can be in the form of:
- a flexible inductor
 - a rigid inductor.

Flexible inductors Flexible inductors, *Figure 1*, are versatile in use and, depending on the application, can be applied in the bore or to the outside diameter of the workpiece. The length of the inductor is defined as a function of the workpiece. Flexible inductors are suitable for the removal and addition of bearing inner rings and the heating of large components such as machine supports in wind energy. Connection to the generator is made using the inductor feed cable HEAT-GENERATOR.CONNECT.



Figure 1
Flexible inductor

00018102

Inductors

The flexible inductors are available in two designs that differ mainly in their geometrical characteristics but also in their maximum operating duration, see table.

Technical data on flexible inductors

Designation		Inductor HEAT-INDUCTOR	
		-.M-D15	-.M
Cooling	–	Air cooling	
Length	m	12 – 16	12 – 40
Diameter	mm	approx. 18	approx. 20
Minimum bending radius	mm	80	150
Mass without plug	kg/m	approx. 0,6	approx. 1
Operating frequency	kHz	10 – 25	
Ambient temperature	°C	0 – +40	
Storage temperature	°C	–5 – +55	
Relative humidity (operation)	–	5% – 80%, non-condensing	
(storage)	–	5% – 80%, non-condensing	
Permissible temperature of workpiece surface	°C	+180	
Maximum temperature at push-fit connector	°C	+90	
Maximum operating duration	–	≤ 10 min	∞
Effective power	–	Dependent on air gap, number of windings and power of generator	
Connection of inductor and generator	–	Push-fit connector	

The flexible inductors are available in various lengths, see table.

Ordering designations and lengths

Ordering designation	Length m
HEAT-INDUCTOR-12M-D15	12
HEAT-INDUCTOR-14M-D15	14
HEAT-INDUCTOR-16M-D15	16
HEAT-INDUCTOR-12M	12
HEAT-INDUCTOR-16M	16
HEAT-INDUCTOR-20M	20
HEAT-INDUCTOR-24M	24
HEAT-INDUCTOR-27M	27
HEAT-INDUCTOR-30M	30
HEAT-INDUCTOR-40M	40

Flexible inductors in other lengths are available by agreement.

Rigid inductors

Rigid inductors are precisely matched in their dimensions to the application. They can also be used, in contrast to flexible inductors, for smaller components, *Figure 2*.

Since they are easy to handle, they are used mainly for batch mounting and dismounting, for example in the mounting of wheelset bearings on rail vehicles. The inductor is located in a heavy-section housing made from temperature-resistant composite material and is monitored for temperature.

Rigid inductors can be designed as internal or external field inductors. In order to achieve faster and more uniform heating, windings can be placed on the outer ring and inner ring of larger rolling bearings at the same time. These are then described as twin inductors.

A rigid inductor is designed within the framework of the configuration of an induction unit for a specific application. The information required for the preparation of a proposal is compiled in a checklist, see page 43.

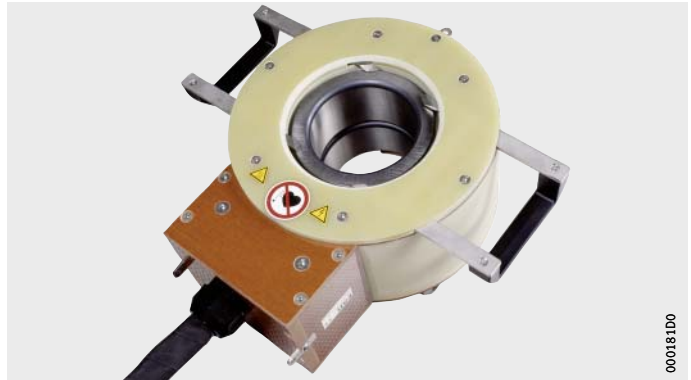

Figure 2
Rigid inductor

Inductors

Accessories This section describes accessories that are available separately.

Magnetic holder The magnetic holder HEAT-INDUCTOR.MAGNET, *Figure 3*, can be used for the rapid fixing of a flexible inductor. Before use, it must be checked whether the high force of the magnet can lead to damage to the workpiece. The magnetisation introduced by the magnet is $> 2 \text{ A/cm}$.



Figure 3
Magnetic holder
HEAT-INDUCTOR.MAGNET

Ordering designation

HEAT-INDUCTOR.MAGNET

Tensioning belt with aluminium holder

The tensioning belt with aluminium holder HEAT-INDUCTOR.BELT, *Figure 4*, can be used where the use of magnetic holders for fixing a flexible inductor is not permitted.

The tensioning belt is suitable for operating temperatures of up to $+100 \text{ }^\circ\text{C}$.



Figure 4
Tensioning belt
with aluminium holder
HEAT-INDUCTOR.BELT

Ordering designation

HEAT-INDUCTOR.BELT

Heat protection cover

The heat protection cover HEAT-INDUCTOR.COVER, *Figure 5*, is used to protect flexible inductors against high temperatures. It comprises knitted silicon oxide fabric and is temperature-resistant up to +500 °C.

The heat protection cover must be used if the workpiece temperature is +180 °C or higher. The flexible inductor itself must not exceed a temperature of more than +180 °C. The heat protection cover must be placed between the workpiece and the flexible inductor such that these are not in contact with each other.



Figure 5
Heat protection cover
HEAT-INDUCTOR.COVER

Ordering designation

HEAT-INDUCTOR.COVER

Tools for mounting

Transport and mounting tool

The transport and mounting tool BEARING-MATE is an accessory for the secure, rapid and easy handling of medium-sized and large rolling bearings. It can also be used where bearings are heated prior to mounting.

The tool comprises two handles and two steel strips. Turning the handles clamps the steel strips firmly on the outer ring of the rolling bearing. The compact packaging also includes two brackets. These are used on self-aligning ball bearings and spherical roller bearings in order to prevent tilting of the inner rings.

The tool and bearing are carried either by two people or a crane. If two carrying slings are used, the rolling bearing can be rotated to any position when transported by crane. During heating on an induction heating device, the tool remains mounted on the bearing. The steel strips expand uniformly with the bearing. Optimum tension is thus maintained.

Scope of delivery

The scope of delivery of BEARING-MATE, *Figure 1*, comprises:

- transport and mounting tool BEARING-MATE
- two short brackets to prevent tilting of the inner rings of self-aligning bearings
- multi-purpose grease Arcanol MULTI2 (20 g tube).



Figure 1
Scope of delivery of
BEARING-MATE

0009C55F

Three tool sizes are available to match different bearing outside diameters, see table.

Ordering designations and dimensions

Ordering designation	Bearing outside diameter		Bearing mass	Operating temperature	Tool mass
	min. mm	max. mm	max. ≈ kg	max. °C	≈ kg
BEARING-MATE250-450	250	450	500	160	6,3
BEARING-MATE450-650	450	650	500	160	6,4
BEARING-MATE650-850	650	850	500	160	6,5

Accessories

The following are available as accessories:

- long brackets to prevent tilting of the inner rings of self-aligning bearings (2 pieces)

Ordering designation: **BEARING-MATE.LOCKBAR270**

Replacement parts

The following are available as replacement parts:

- short brackets to prevent tilting of the inner rings of self-aligning bearings (2 pieces)

Ordering designation: **BEARING-MATE.LOCKBAR170**

- pack of small parts with replacement labels for the BEARING-MATE and a 20 g tube of Arcanol MULTI2

Ordering designation: **BEARING-MATE.SERVICE-KIT**

Services

Extensive service portfolio

Schaeffler offers, irrespective of the manufacturer of the bearing arrangement, a wide range of services relevant to the lifecycle of a rolling bearing: starting with mounting and progressing through maintenance to the reconditioning of rolling bearings.

During the operational phase, the Schaeffler experts provide support through services in the fields of condition monitoring and corrective maintenance. Companies that wish to build up their knowledge in the areas of rolling bearings and condition monitoring also have access to the Schaeffler training and consultancy portfolio on site, centrally or online. Our e-learning portfolio on the Internet provides the first steps into this field. In this way, customers benefit from the expertise of a leading supplier of rolling and plain bearings.

Mounting and dismounting services

The Schaeffler Industrial Service experts offer mounting and dismounting services for rolling bearings that are applicable across industrial sectors. They have detailed knowledge and extensive experience in all industrial sectors.

The experts in the Industrial Service function are trained and skilled personnel who can provide reliable, rapid and competent assistance. The services are provided worldwide, either on site at your location or in Schaeffler workshop facilities.

If the customer takes up a mounting or dismounting service, he will save himself the procurement of the necessary devices, tools and measuring equipment.

Schaeffler also offers a rental service for special mounting and dismounting tools as well as measuring equipment.

Scope of mounting and dismounting services

The mounting and dismounting services, *Figure 1*, include:

- mounting and dismounting of rolling bearings, plain bearings and bearing systems of all types by experts available worldwide
- measurement and condition analysis of bearing arrangements
- problem solving and preparation of concept solutions
- design and manufacture of special tools
- leasing of tools (only available in Europe)
- emergency service
- training courses on products and mounting
- certification of mounting and dismounting processes.

Figure 1
Mounting services



Advantages

The mounting services give the following advantages:

- readily available service worldwide
- rapid mounting or dismounting through precise preparation
- professional mounting and dismounting using special high-quality tools
- increased plant availability and productivity as a result of reduced unplanned downtime
- correct use of bearings of all types as a result of customer training.

Other services

In addition to mounting and dismounting services, Schaeffler offers services covering the following areas:

- lubrication
- condition monitoring
- corrective maintenance
- rolling bearing reconditioning
- technical advice
- TCO approach
- training courses.

Further information

- Catalogue IS 1, Mounting and Maintenance of Rolling Bearings
- Contact: mounting-services@schaeffler.com.



Application examples

Dismounting of inner rings

In the forming of steel and non-ferrous metals on hot and cold rolling stands, the rolling bearings used there operate under high loads. This requires frequent and intensive maintenance of the rolling bearings.

Due to their high radial load carrying capacity, four-row cylindrical roller bearings are often used as back-up roll bearings, *Figure 1*. In dismounting, the housings are removed from the roll journal together with the bearing inner rings and the roller and cage assemblies. The inner rings have a tight fit on the roll journal and must then be dismantled.

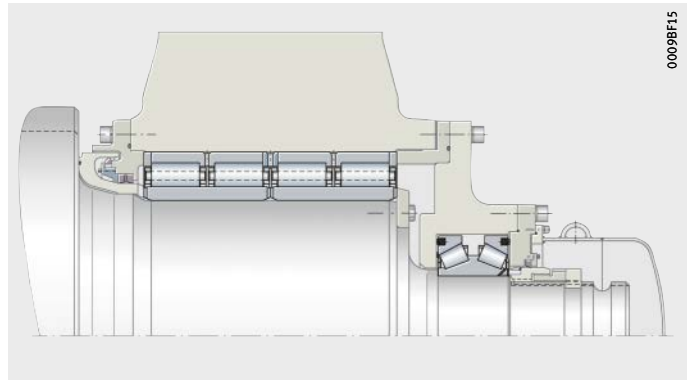

Figure 1
Four-row cylindrical roller bearing
in a back-up roll on a rolling stand

Requirements

The inner rings to be dismantled each have a bore diameter of 780 mm, a width of 390 mm and a mass of approx. 280 kg.

In order to eliminate the tight fit on the roll journal, the rings must be heated in a short time from +20 °C to +100 °C. In this process, the roll journal may only be heated additionally to a small extent, since this is the only way to create sufficient joint clearance for removal between the inner ring and the roll journal.

Solution

For heating, an induction unit with medium frequency technology is used. The two inner rings are consecutively heated and dismantled. The flexible inductor is wound about the inner ring and a temperature sensor is attached to the inner ring. With the aid of temperature regulation, the inner ring is heated to the set temperature. The heating time is only approx. 7 minutes.

Due to the rapid heating and the skin effect active in the induction method, targeted heating of the inner ring is possible without excessive heating of the roll journal.

The figures show, using a training example, the correct way of winding on the inner ring, *Figure 2*, and removal of the heated inner rings from the roll journal, *Figure 3*.



Figure 2
Induction heating of inner ring



Figure 3
Transport and dismounting tool
BEARING-MATE

Products used

For dismounting of the inner rings, an induction unit with medium frequency technology of the following configuration is used:

- generator HEAT-GENERATOR40-2
- flexible inductor HEAT-INDUCTOR-27M
- inductor feed cable HEAT-GENERATOR.CONNECT.

For removal of the heated inner rings:

- transport and mounting tool BEARING-MATE650-850.

Batch mounting of bearings in housing

A brown coal power station operated by a leading energy company in Eastern Europe uses almost 100 impact wheel mills. They are used for the crushing of brown coal in order to supply the combustion chambers with coal dust. Due to the extreme loads present, the rolling bearings in the impact wheel mills must be replaced regularly.

Requirements

In each impact wheel mill, two spherical roller bearings must be replaced. Due to the transition fit at the bearing seat, mounting of each new bearing requires heating of the bearing seat together with the housing in order to create the requisite joint clearance.

The customer previously used a gas burner for heating since, due to the very large housing dimensions and the large mass of 3,6 t, a conventional heating device could not be used. This method involved a large injury hazard and the risk of non-uniform material expansion, which could cause damage to the bearing seat. Furthermore, heating of the components took several hours. The task for Schaeffler was to make the heating process faster, safer and more cost-effective.

Solution

The induction unit with medium frequency technology that was specially designed for the task described comprises a generator and two rigid inductors for the two different bearing seats. The inductors of a rigid design are particularly suitable for the batch operation required.

- ① Rigid inductor
- ② Bearing seat
- ③ Housing

Figure 1
Housing with inductor
in mounting position



For heating, the inductor is placed in the bearing seat, *Figure 1*. At a power of max. 20 kW and an operating frequency of 10 kHz to 25 kHz, the bearing seat is heated with temperature control in only approx. 20 minutes to +60 °C. This temperature ensures sufficiently large clearance for mounting of the bearing.

In comparison with the gas burner, the medium frequency technology reduces the time outlay for bearing replacement by several hours per bearing. Furthermore, safety of man and machine is increased, since the component is heated in a controlled manner by the temperature-controlled process and without a naked flame. Overall, there is a significant increase in efficiency relating to time outlay, use of resources and energy consumption, which also gives a considerable increase in plant availability.

Advantages compared to heating by means of gas burner

Aspect	Gas burner	Induction unit
Work preparation	Demanding	Low
Use of resources	Several persons	1 person
Occupational safety	Problematic	High
Heating time	Several hours	20 minutes

Products used

For mounting of the bearings in the housing, an induction unit with medium frequency technology of the following configuration is used:

- HEAT-GENERATOR20-2
(replacing the previously used HEAT-GENERATOR20-BASIC)
- HEAT-INDUCTOROUT760×306
- HEAT-INDUCTOROUT870×365.

Batch mounting of large spherical roller bearings

The application considered in the following example concerns the mounting of the main bearing arrangement in a wind turbine with a power rating of 3,6 MW. In the case of the 3 point support applied here, very large spherical roller bearings are used that must be mounted with a tight fit on the main shaft.

Requirements

The spherical roller bearings to be mounted have an outside diameter of up to 1400 mm and a maximum mass of approx. 1320 kg. Several of these bearings must be mounted each day. In order to overcome the fit conditions, a temperature differential of 80 Kelvin must be achieved between the shaft and inner ring for mounting.

The spherical roller bearings are not separable. If only the inner ring was heated but the outer ring was not heated at the same time, a large preload would be induced in the bearing.

As a result, the rolling elements could cause indentations in the raceways that would render the bearings unusable. In order to prevent such damage, the inner ring and outer ring must be subjected to simultaneous, matched heating.

The task for Schaeffler was to develop a rapid and energy-efficient mounting process appropriate to batch operation. In addition to the heating itself, simple handling of the heated bearing was also necessary.

Solution

For heating of the spherical roller bearings, an induction unit with medium frequency technology is used. A twin inductor specially matched to the bearing size was designed. The twin inductor has two separate windings that form an internal field inductor and external field inductor. The windings are thus arranged in a common housing such that one heats the inner ring while the other heats the outer ring, *Figure 1*.

- ① Main shaft of wind turbine
- ② Twin inductor
- ③ Spherical roller bearing

Figure 1

Application example:
Twin inductor with bearing and shaft

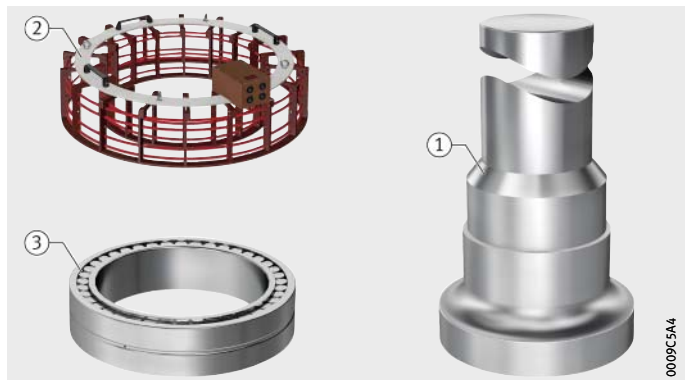

Each winding is connected to a separate generator. The two generators are run using master/slave operation and matched to each other.

The twin inductor is guided by a crane into a horizontal position above the bearing, *Figure 2*.



Figure 2
Twin inductor above spherical roller bearing to be heated

The heating time with the twin inductor is only approx. 35 minutes, which is a reduction of more than 50% compared to the conventional mounting process.

After heating, the bearing is transported by crane directly from its lying position for mounting and is mounted on the shaft.

In summary, the solution with medium frequency technology has the following advantages:

- safe heating of the spherical roller bearings
- short heating times and low energy costs
- simple handling appropriate to batch operation.

Products used

The induction unit with medium frequency technology used comprises:

- 2 generators HEAT-GENERATOR20-2
- twin inductor HEAT-INDUCTOR-TWIN1060×1400×310
- inductor feed cable HEAT-GENERATOR.CONNECT.

Batch dismantling of labyrinth and inner rings

Due to defined maintenance intervals, wheelset bearings on rail vehicles must be subjected to regular inspection and maintenance. Dismounting of the wheelset bearings is thus necessary. In the application example described here, FAG cylindrical roller bearings WJ/WJP120×240 and WJ/WJP130×240 are used. The bearings are separable, which means that the inner rings and the associated labyrinth rings can be dismantled using induction.

Requirements

The requirements are as follows:

- removal of normally large quantities, in some cases in shift operation
- rapid, safe, energy-efficient and environmentally compatible dismantling
- reuse of the bearings where suitable
- controlled and uniform heating with subsequent demagnetisation, which is important for process reliability.

Solution

For dismantling of the wheelset bearings described, an induction unit with medium frequency technology of the following configuration is used:

- HEAT-GENERATOR20-RAIL, *Figure 1*
- HEAT-INDUCTOR-IN157×145, *Figure 2*
- HEAT-INDUCTOR-LAB176×50, *Figure 3*.



Figure 1
HEAT-GENERATOR20-RAIL

0009E21E

- ① HEAT-INDUCTOR-IN157×145
- ② Spacer ring

Figure 2
HEAT-INDUCTOR-IN157×145
with spacer ring

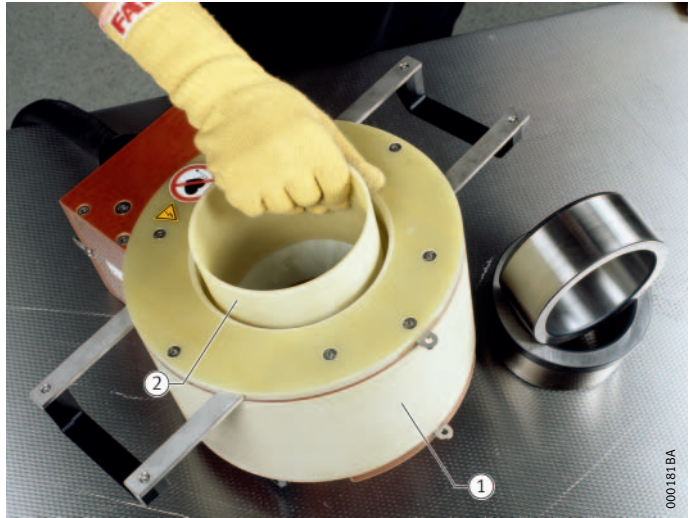
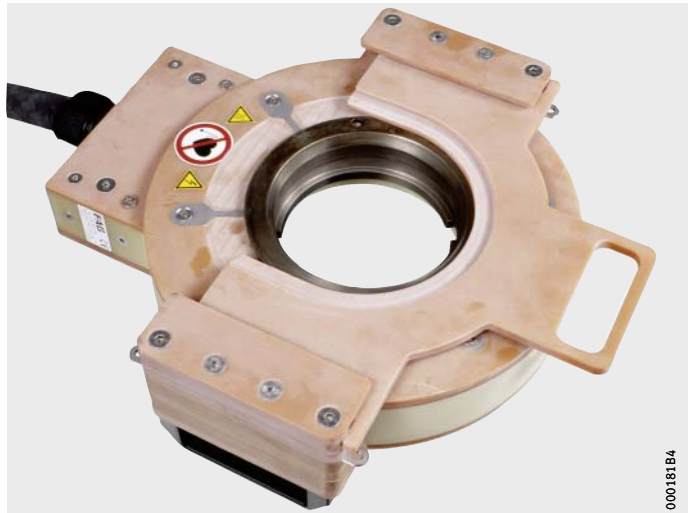

Figure 3
HEAT-INDUCTOR-LAB176×50
for dismounting of labyrinth rings



The induction unit can be operated by open or closed loop control. This gives temperature-dependent shutdown of the coils. The operating mode is selected by means of a key switch.

The temperature of the workpiece is measured by means of a type K thermocouple with a magnetic clamp. In order to prevent overheating of the coils, the temperature of the winding in the inductors is also monitored by means of a thermistor.

A coded push-fit connector signals to the generator whether the inductor for bearing inner rings or for labyrinth rings is connected.

Batch dismantling of labyrinth and inner rings

Operating modes

The generator detects the inductor via the coded push-fit connector and automatically selects the operating mode specified for the relevant inductor.

Operation of inductor for bearing inner rings

The power specification is set in advance by means of a potentiometer that is not accessible to the operator. The heating time is specified by means of a timer. The temperature is measured via the magnetic sensor. The generator shuts down once the time has expired or the maximum temperature is reached. The controller and timer are locked to the operator.

Operation of inductor for labyrinth rings

The power specification is set by means of a potentiometer. The heating time is specified by means of a second timer. The temperature is measured via the magnetic sensor. The generator shuts down once the time has expired or the maximum temperature is reached. Selection is made by means of a key switch. The second controller and timer are accessible to the operator.

Dismounting of bearing inner rings

Operations for the dismantling of bearing inner rings:

- The bearing inner rings and adjacent parts are cleaned.
- For dismantling of the bearing WJ/WJP120×240, the spacer ring supplied must be used, *Figure 4, ①*.
- The inductor is slid onto the inner ring and the slider on the rear face is closed.
- The magnetic temperature sensor is applied to the end face of the bearing inner ring, *Figure 4, ②*.
- Once the requisite heating temperature has been reached, the generator shuts down automatically. The inner ring is removed together with the inductor.
- Finally, the inner ring is removed promptly from the inductor.

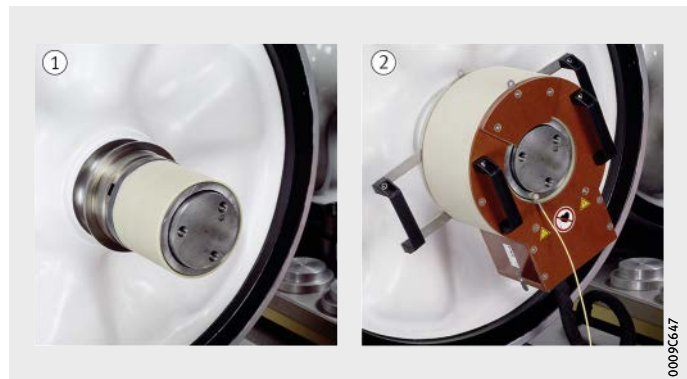

Figure 4
Dismounting of
bearing inner rings

Dismounting of labyrinth rings

Operations for the dismounting of labyrinth rings:

- Depending on the labyrinth ring design, a spacer ring is used.
- The inductor is slid into place and the appropriate slider for gripping behind the labyrinth rings is selected and closed, *Figure 5, ①*.
- The magnetic temperature sensor is applied to the end face of the labyrinth ring, *Figure 5, ②*.
- Once the requisite heating temperature has been reached, the generator shuts down automatically. The labyrinth ring is removed together with the inductor.
- Finally, the slider is removed and the inner ring is removed from the inductor.

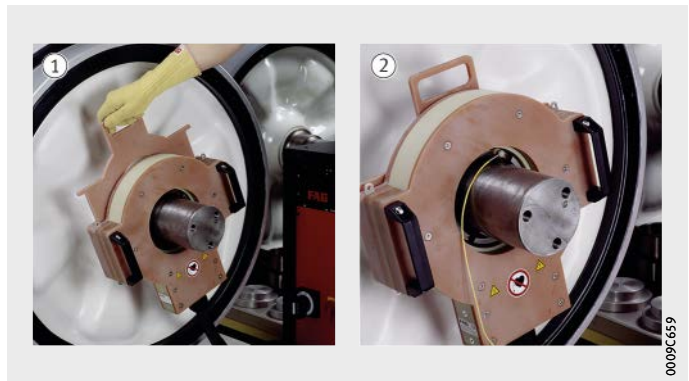

Figure 5
Dismounting of
labyrinth rings

Batch dismantling of labyrinth and inner rings

Products used

For dismantling of the wheelset bearings described, an induction unit with medium frequency technology of the following configuration is used:

- HEAT-GENERATOR20-RAIL
- HEAT-INDUCTOR-IN157×145
- HEAT-INDUCTOR-LAB176×50.

Technical data HEAT-GENERATOR20-RAIL

Designation	Value
Power	20 kW
Controller	Analogue
Power protection	20 A
Width	550 mm
Depth	500 mm
Height	410 mm
Mass	40 kg

Technical data HEAT-INDUCTOR-IN157×145

Designation	Value
Bearing type	WJ/WJP120×240
	WJ/WJP130×240
Outside diameter	300 mm
Width	165 mm
Mass	12 kg

Technical data HEAT-INDUCTOR-LAB176×50

Designation	Value
Bearing type	Labyrinth rings
Outside diameter	340 mm
Width	90 mm
Mass	8 kg

Information required for preparation of proposal



Please mark as appropriate

Mounting Dismounting Mounting and dismounting

Contact information

Company name	_____	Contact	_____
Street, number	_____	Telephone	_____
Postcode, town	_____	Fax	_____
Country	_____	E-mail	_____
Market sector	_____	Other information	_____

Technical data on the workpieces to be heated (especially if these are not FAG rolling bearings)

Bearing designation, bearing drawing _____

Bore diameter d _____

Raceway diameter F _____

Width B _____

Material _____

Other workpieces (attach drawing/diagram) _____

Alternative main dimensions

Bore diameter d _____

Outside diameter D _____

Width B _____

Maximum fit interference or tolerance classes of both workpieces

Approximate number of heating operations

Quantity _____ per day week month year

Electricity supply available at workstation

Mains voltage in V and Hz _____

Maximum power capacity of grid in A _____

Miscellaneous

Climatic conditions _____

Environment _____

**Schaeffler Technologies
AG & Co. KG**

Postfach 1260
97419 Schweinfurt
Germany

Georg-Schäfer-Straße 30
97421 Schweinfurt
Germany

Phone +49 2407 9149-66

Fax +49 2407 9149-59

E-mail support.is@schaeffler.com

Internet www.schaeffler.com/services

Every care has been taken to ensure the correctness of the information contained in this publication but no liability can be accepted for any errors or omissions.

We reserve the right to make technical changes.

© Schaeffler Technologies AG & Co. KG

Issued: 2016, December

This publication or parts thereof may not be reproduced without our permission.

TPI 217 GB-D