

**FAG**



## **Arcanol Rolling Bearing Greases**

For reliable, durable and  
cost-effective bearing arrangements

**SCHAEFFLER**



# Foreword

## Portfolio

An essential factor for the performance capability and the rating life of a rolling bearing or a linear unit is the correct selection of a suitable grease. With the competence available at Schaeffler, the rolling bearing or linear system as a machine element can be given advantages in terms of reliability and rating life on the way to realising an application. For decades, Schaeffler has been carrying out research in the development and application of greases in order to determine which grease provides the best solution for each application.

Arcanol greases have for decades been a guarantee of the highest performance capability in rolling bearing and linear applications. All Arcanol greases have been subjected to a demanding test of suitability.

In 2015 alone, Schaeffler used its own FE8 and FE9 test rigs to carry out more than 50 000 hours of tests, *Figure 1* and *Figure 2*. These hours of testing lay the foundations that allow you the best possible benefits from this know-how.

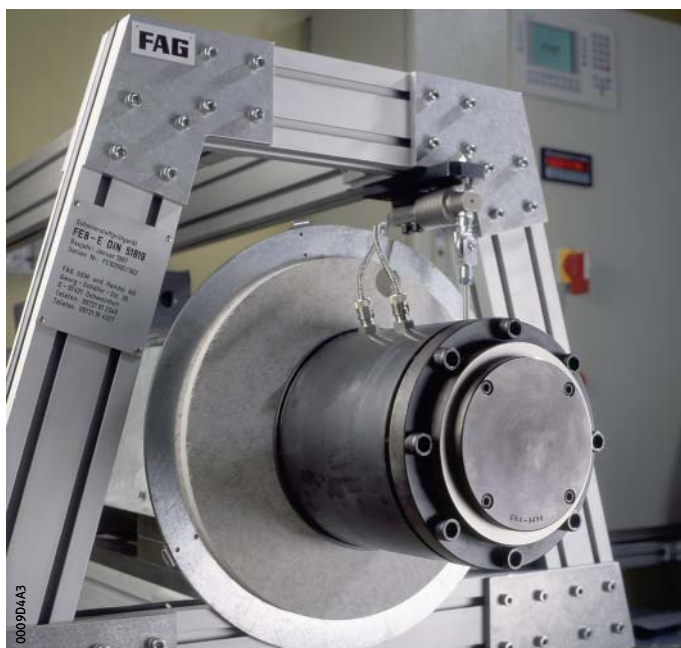

*Figure 1*  
FE8 test rig

## Foreword



*Figure 2*  
FE9 test rig

You can use our knowledge of the interactions between rolling bearings and greases to find the best possible solution for your application.

Based on the test rig work, a range of greases has been developed under the brand Arcanol that is subdivided into four groups:

- Multipurpose greases:
  - greases with a wide range of applications
- Heavy duty greases:
  - greases suitable for high demands on load carrying capacity
- High temperature greases:
  - greases that must withstand high application temperatures
- Special greases:
  - greases that have been specially selected for a particular area of application.

**Consistent product quality as  
a result of comprehensive  
quality inspection**

Each delivery of Arcanol greases is subjected to comprehensive quality inspection. The quality of each batch can be clearly demonstrated and identified. In the in-house analysis laboratory, the chemical and physical characteristics of Arcanol greases are tested in accordance with strict test guidelines. Thanks to decades of experience, Schaeffler can also ensure in this respect that its customers always receive the highest level of product quality.

# Contents

	Page
Rolling bearing greases Arcanol .....	8
Influence of load .....	8
Influence of water and moisture .....	8
Influence of oscillations, shocks and vibrations.....	9
Contaminants in the lubricant .....	10
Solid foreign matter.....	10
Liquid contaminants.....	11
Cleaning of contaminated bearings.....	12
Miscibility of greases and oils .....	12
Supply of lubricant to bearings.....	14
Initial greasing and new greasing.....	15
Grease operating life .....	17
Relubrication interval .....	24
Relubrication and relubrication intervals.....	25
Examples of grease lubrication .....	26
Storage of lubricants.....	32
Disposal .....	32
Universal greases .....	34
Arcanol MULTITOP.....	34
Arcanol MULTI2.....	36
Arcanol MULTI3.....	38
Heavy duty greases .....	40
Arcanol LOAD150.....	40
Arcanol LOAD220.....	42
Arcanol LOAD400.....	44
Arcanol LOAD460.....	46
Arcanol LOAD1000.....	48

	Page
High temperature greases.....	50
Arcanol TEMP90 .....	50
Arcanol TEMP110 .....	52
Arcanol TEMP120 .....	54
Arcanol TEMP200 .....	56
Special greases.....	58
Arcanol SPEED2,6.....	58
Arcanol VIB3 .....	60
Arcanol FOOD2.....	62
Arcanol CLEAN-M.....	64
Arcanol MOTION2 .....	66
Arcanol MOUNTINGPASTE .....	68
Arcanol ANTICORROSIONOIL .....	69
Relubrication devices.....	70
Lubricator FAG CONCEPT2.....	70
Lubrication system FAG CONCEPT8 .....	72
Minimal quantity lubrication device CONCEPT PRECISION GREASE.....	74
Lubrication lexicon .....	76

Grease	Characteristic applications	Operating temperature		Continuous limit temperature °C	Thickener
		°C			
		from	to		
Multipurpose greases	MULTITOP <ul style="list-style-type: none"> <li>Ball and roller bearings in rolling mills</li> <li>Construction machinery</li> <li>Spinning and grinding spindles</li> <li>Automotive engineering</li> </ul>	-50 <sup>1)</sup>	+140	+80	Lithium soap
	MULTI2 <ul style="list-style-type: none"> <li>Ball bearings up to 62 mm outside diameter in large electric motors</li> <li>Agricultural and construction machinery</li> <li>Household appliances</li> </ul>	-30	+120	+75	Lithium soap
	MULTI3 <ul style="list-style-type: none"> <li>Ball bearings of or over 62 mm outside diameter in large electric motors</li> <li>Agricultural and construction machinery</li> <li>Fans</li> </ul>	-30	+120	+75	Lithium soap
High loads	LOAD150 <ul style="list-style-type: none"> <li>Ball, roller and needle roller bearings</li> <li>Linear guidance systems in machine tools</li> </ul>	-20	+140	+95	Lithium complex soap
	LOAD220 <ul style="list-style-type: none"> <li>Ball and roller bearings in rolling mill equipment</li> <li>Paper machinery</li> <li>Rail vehicles</li> </ul>	-20	+140	+80	Lithium/calcium soap
	LOAD400 <ul style="list-style-type: none"> <li>Ball and roller bearings in mining machinery</li> <li>Construction machinery</li> <li>Wind turbine main bearings</li> </ul>	-40	+130	+80	Lithium/calcium soap
	LOAD460 <ul style="list-style-type: none"> <li>Ball and roller bearings</li> <li>Wind turbines</li> <li>Bearings with pin cage</li> </ul>	-40 <sup>1)</sup>	+130	+80	Lithium/calcium soap
	LOAD1000 <ul style="list-style-type: none"> <li>Ball and roller bearings in mining machinery</li> <li>Construction machinery</li> <li>Cement plant</li> </ul>	-30 <sup>1)</sup>	+130	+80	Lithium/calcium soap
High temperatures	TEMP90 <ul style="list-style-type: none"> <li>Ball and roller bearings in couplings</li> <li>Electric motors</li> <li>Automotive engineering</li> </ul>	-40	+160	+90	Polycarbamide
	TEMP110 <ul style="list-style-type: none"> <li>Ball and roller bearings in electric motors</li> <li>Automotive engineering</li> </ul>	-35	+160	+110	Lithium complex soap
	TEMP120 <ul style="list-style-type: none"> <li>Ball and roller bearings in continuous casting plant</li> <li>Paper machinery</li> </ul>	-30	+180	+120	Polycarbamide
	TEMP200 <ul style="list-style-type: none"> <li>Ball and roller bearings in guide rollers for baking machinery</li> <li>Kiln trucks and chemical plant</li> <li>Piston pins in compressors</li> </ul>	-30	+260	+200	PTFE
Special requirements	SPEED2,6 <ul style="list-style-type: none"> <li>Ball bearings in machine tools</li> <li>Spindle bearings</li> <li>Rotary table bearings</li> <li>Instrument bearings</li> </ul>	-40	+120	+80	Lithium complex soap
	VIB3 <ul style="list-style-type: none"> <li>Ball and roller bearings in wind turbine rotors (blade adjustment)</li> <li>Packaging machinery</li> <li>Rail vehicles</li> </ul>	-30	+150	+90	Lithium complex soap
	FOOD2 <ul style="list-style-type: none"> <li>Ball and roller bearings in applications with food contact (NSF-H1 registration, kosher and halal certification)</li> </ul>	-30	+120	+70	Aluminium complex soap
	CLEAN-M <ul style="list-style-type: none"> <li>Ball, roller and needle roller bearings as well as linear guidance systems in clean room applications</li> </ul>	-30	+180	+90	Polycarbamide
	MOTION2 <ul style="list-style-type: none"> <li>Ball and roller bearings in oscillating operation</li> <li>Slewing rings in wind turbines</li> </ul>	-40	+130	+75	Lithium soap

+++ Extremely suitable. ++ Highly suitable. + Suitable. - Less suitable. -- Not suitable.

<sup>1)</sup> Measurement values according to Schaeffler FE8 low temperature test.



Base oil	Consistency NLGI	Base oil viscosity at +40 °C mm <sup>2</sup> /s	Temperatures		Low friction, high speed	High load, low speed	Vibrations	Seal support	Relubrication facility
			Low	High					
Partially synthetic oil	2	82	+++	++	++	+++	++	+	+++
Mineral oil	2	110	++	+	+	+	+	+	+++
Mineral oil	3	80	++	+	+	+	++	++	++
Mineral oil	2	160	+	++	-	+++	++	++	++
Mineral oil	2	245	+	+	-	+++	++	++	++
Mineral oil	2	400	+	+	-	+++	++	++	++
Mineral oil	1	400	++	+	-	+++	++	-	++
Mineral oil	2	1 000	+	+	--	+++	++	++	++
Partially synthetic oil	3	148	+++	++	+	+	+	++	++
Partially synthetic oil	2	130	+++	+++	++	+	+	+	+
Synthetic oil	2	400	++	+++	-	+++	+	++	+
Alkoxyfluoro oil	2	550	++	+++	--	++	+	+	+
Synthetic oil	2 – 3	25	+++	+	+++	--	-	+	+
Mineral oil	3	170	++	++	-	++	+++	++	-
Synthetic oil	2	150	++	-	+	+	+	+	+++
Ether oil	2	103	+++	+++	+	+	+	+	++
Synthetic oil	2	50	+++	+	-	++	+++	++	+

# Rolling bearing greases Arcanol

## Features

### Influence of load

For a load ratio  $C/P < 10$  or respectively  $P/C > 0,1$ , greases are recommended that have higher base oil viscosity and in particular anti-wear additives (EP). These additives form a reaction layer on the metal surface that gives protection against wear. Such greases are identified in accordance with DIN 51825 by KP. Their use is also recommended for bearings with an increased proportion of sliding motion (including slow running) or line contact as well as under combined loads (radial, axial). Greases with solid lubricants such as PTFE or molybdenum disulphide should be used in preference for applications in the boundary or mixed friction range (chemical lubrication). The solid lubricant particle size must not exceed a value of 5  $\mu\text{m}$ .

### Influence of water and moisture

Moisture can enter the bearing from outside if the application is operated in a damp environment, for example outdoors. Water may condense within the bearing if there are rapid temperature changes between warm and cold. This may occur in particular if there are large cavities in the bearing or housing. Water can cause severe damage to the grease or bearing. This is due to ageing or hydrolysis, interruption of the lubricant film and not least corrosion. Calcium complex soap greases have proved effective here since they have good water resistance or act to repel water. The anti-corrosion effect of a grease is also influenced by additives. This is tested using the SKF Emcor method in accordance with ISO 11007 or DIN 51805. Greases of type K in accordance with DIN 51825 must have a corrosion level  $< 1$ . Further information, see page 11.

## **The influence of oscillations, shocks and vibrations**

Oscillation loads can have a considerable effect on the structure of thickeners in greases. If mechanical stability is not sufficient, changes in consistency may occur. This leads to softening, deoiling or in isolated cases also hardening of the grease with a corresponding reduction in lubrication capability. It is therefore recommended that a grease should be selected whose mechanical stability has been tested accordingly. The options here are the expanded worked penetration, the Shell Roller Test in accordance with ASTM D 1831 and a test run on the FAG AN42 test rig.

Under shock type load or very high load, it is advantageous to use greases of consistency grade NLGI 1 to NLGI 2 with a high base oil viscosity (ISO VG 460 to ISO VG 1500). Due to their high base oil viscosity, these greases form a comparatively thick, elastohydrodynamic lubricant film that gives damping of shocks.

However, the disadvantage of greases with a high base oil viscosity is that, due to the low oil release rate, it must be ensured that the lubricant is present to an effective extent at the contact by a high fill level or shorter term relubrication.

If very small swivel angles and vibrations are present, there is a danger of so-called false brinelling. In order to counteract this wear mode, which has not so far been fully researched, the use of special lubricants and in special cases also coatings has proved to be advantageous. The decisive factor here is the correct combination of the base oil and thickener type, base oil viscosity, consistency, additive package and, as appropriate, solid lubricants.

For such applications, the greases Arcanol LOAD150, Arcanol VIB3 or Arcanol MOTION2 can be used. Which grease is the suitable solution in an individual case can be clarified with Schaeffler Application Engineering.

# Rolling bearing greases Arcanol

## Contaminants in the lubricant

In practice, there are hardly any lubrication systems that are completely free of contaminants. Contaminants that are common to applications are already taken into consideration in determining the fatigue life and operating life, since the calculation methods are based on results from practice and tests. If a level of contamination higher than in the normal application is unavoidable, this will lead to reduced running times or premature failures. If the level of cleanliness is particularly good, however, longer running times can be achieved.

At the time of initial mounting, contaminants often also enter the bearing due to inadequate cleaning of machine parts. Contaminants may also enter the bearing during maintenance, for example due to contamination on the lubrication nipple or on the nozzle of the grease gun as well as during greasing by hand.

When determining the harmful influence of contaminants, the following are particularly important for all lubricants:

- the type and hardness of foreign matter
- the concentration of foreign matter in the lubricant
- the particle size of the foreign matter.

## Solid foreign matter

Solid foreign matter leads to wear and premature fatigue. The higher the hardness of the overrolled particles (for example iron swarf, grinding swarf, moulding sand, corundum) and the smaller the bearings, the greater the reduction in the life.

## Reduction in the concentration of foreign matter

The concentration of foreign matter is reduced by:

- clean lubricants
- effective sealing
- thorough cleaning of parts adjacent to the bearing
- cleanliness during mounting
- sufficiently short grease change intervals.

### Liquid contaminants

The harmful effect of liquid contaminants in the lubricant is often seriously underestimated. Even pure water without additional aggressive media has very high potential for damage in rolling bearings.

The potential for damage is divided into the following categories:

- reduction in the fatigue running time
- cause of wear
- acceleration of lubricant ageing and formation of residues
- corrosion.

The damage mechanisms occur individually or in combination and are dependent on the lubricant type, bearing material and the free quantity of water carried in with the lubricant. They can lead to functional incapacity or can completely destroy the bearing.

### The influence of water in greases

In grease, water causes structural changes depending on the thickener type. There is a risk that the greases will undergo considerable softening. The damage mechanisms are comparable with those in oils. Greases have the advantage that contaminated lubricant does not necessarily enter the contact and does not flow in when water is vapourised. If there is ingress of water, the grease change interval must be shortened in accordance with the quantity of water present. The action of the grease in supporting sealing is applied in labyrinth lubrication. Aggressive substances such as acids, bases or solvents lead to major changes in the chemical/physical key data and principally to lubricant ageing and corrosion. If such contaminants are expected, the compatibility data from lubricant manufacturers must be considered. At points that are not protected from the lubricant, corrosion will occur sooner or later depending on the aggressiveness of the contaminant and will destroy the surface.

# Rolling bearing greases Arcanol

## Cleaning of contaminated bearings

All parts that are removed from undamaged original packaging are very clean and do not require cleaning. Cleaning in this case would very probably impair the original condition. Parts that have become contaminated as a result of environmental influences can be cleaned using petroleum ether, petroleum, spirit, dewatering fluids, aqueous, neutral and also alkaline cleaning agents. It must be noted that petroleum, petroleum ether, spirit and dewatering fluids are flammable and alkaline agents are corrosive. The washing process should be carried out using brushes, paint brushes or lint-free cloths.

After washing, the parts must be:

- additionally cleaned using a very clean rinsing medium appropriate to the washing chemicals
- subsequently dried
- protected immediately using preservation in order to prevent corrosion.

Compatibility of the preservation with the lubricant used must be observed. If the bearings contain resinous oil or grease residues, precleaning by mechanical means followed by longer softening with an aqueous, strongly alkaline cleaning agent is recommended.

## Miscibility of greases and oils

Where possible, greases should not be mixed with each other at all. On the one hand, the base oils of greases and their thickeners may not be compatible, see tables. On the other hand, the effect of additives and the performance capability of lubricant mixtures cannot be estimated without appropriate testing.

If mixing cannot be avoided, however, it is recommended that the following points should be observed:

- identical base oil
- compatible thickener type
- similar base oil viscosities  
(different by no more than one ISO-VG grade)
- identical consistency (NLGI grade).

In mixing, there is nevertheless a risk that softening of the grease or a reaction between the additives of the two greases will occur. Both of these can lead to a reduction in performance capability.

### Miscibility of base oils

	Mineral oil	PAO	Ester oil	Polyglycol oil	Silicone oil	Alkoxyfluoro oil
Mineral oil	+	+	+	–	o	–
PAO	+	+	+	–	o	–
Ester oil	+	+	+	o	–	–
Polyglycol oil	–	–	o	+	–	–
Silicone oil	o	o	–	–	+	–
Alkoxyfluoro oil	–	–	–	–	–	+

- + Mixing is generally non-critical.
- o Miscible in individual cases, but checking should be carried out.
- Mixing not permissible.

### Compatibility of different thickener types

	Lithium soap	Lithium complex	Sodium complex	Calcium complex	Aluminium complex
Lithium soap	+	+	–	+	–
Lithium complex	+	+	o	+	o
Sodium complex	–	o	+	o	o
Calcium complex	+	+	o	+	o
Aluminium complex	–	o	o	o	+
Barium complex	+	o	o	o	o
Bentonite	–	–	–	o	–
Polycarbamide	–	o	o	o	–
PTFE	+	+	+	+	+

- + Mixing is generally non-critical.
- o Miscible in individual cases, but checking should be carried out.
- Mixing not permissible.

### Compatibility of different thickener types (continued)

	Barium complex	Bentonite	Polycarbamide	PTFE
Lithium soap	+	–	–	+
Lithium complex	o	–	o	+
Sodium complex	o	–	o	+
Calcium complex	o	o	o	+
Aluminium complex	o	–	–	+
Barium complex	+	+	o	+
Bentonite	+	+	–	+
Polycarbamide	o	–	+	+
PTFE	+	+	+	+

- + Mixing is generally non-critical.
- o Miscible in individual cases, but checking should be carried out.
- Mixing not permissible.

## Rolling bearing greases Arcanol



Before mixing, the lubricant manufacturer must always be consulted. Even if the preconditions are fulfilled, the performance capability of the mixed grease may be impaired. Relubrication should only be carried out using greases of comparable performance capability. If a different grease grade is to be used, the previous grease must first be flushed out as far as this is permitted by the design.

Further relubrication should be carried out after a shortened period. If incompatible greases are mixed, this can lead to considerable structural changes. Substantial softening of the grease mixture may also occur.

### Supply of lubricant to bearings

The lubricant quantity actually required by a rolling bearing is extraordinarily small. Due to the operational reliability of the bearing arrangement, however, it is normally estimated at a higher value in practice. However, too much lubricant in the bearing can lead to damage. If excess lubricant cannot escape, the splashing or churning work will lead to temperatures at which the lubricant may be impaired or even destroyed.

In general, an adequate supply is ensured through the following:

- selection of the correct lubricant quantity and distribution in the bearing
- attention to the operating life of the lubricant
- appropriate addition of lubricant or lubricant replacement
- targeted design of the bearing position
- the necessary devices and lubrication method.

In the case of grease lubrication, little or no work on devices is normally required in order to lubricate the bearings adequately. If the bearings fitted do not have an initial greasing carried out by the manufacturer, the bearings are frequently greased by hand when they are mounted. In many cases, this is assisted by the use of injection syringes or grease guns.



## Initial greasing and new greasing

In the greasing of bearings, the following guidelines must be observed:

- Fill the bearings such that all functional surfaces definitely receive grease.
- Fill any housing cavity adjacent to the bearing with grease only to the point where there is still sufficient space for the grease displaced from the bearing. This is intended to avoid co-rotation of the grease. If a large, unfilled housing cavity is adjacent to the bearing, sealing shields or washers as well as baffle plates should be used to ensure that an appropriate grease quantity (similar to the quantity that is selected for the normal degree of filling) remains in the vicinity of the bearing. A grease filling of approx. 90% of the undisturbed free bearing volume is recommended. This is defined as the volume in the interior of the bearing that does not come into contact with rotating parts (rolling elements, cage).
- In the case of bearings rotating at very high speeds, such as spindle bearings, a smaller grease quantity is generally selected (approx. 60% of the undisturbed free bearing volume or approx. 30% of the total free bearing volume), in order to aid grease distribution during starting of the bearings.
- The sealing action of a gap seal is improved by the formation of a stable grease collar. This effect is supported by continuous relubrication.
- If the correct degree of filling is used, favourable friction behaviour and low grease loss will be achieved.
- If there is a pressure differential between the two sides of the bearing, the flow of air may drive the grease and the released base oil out of the bearing and may also carry contamination into the bearing. In such cases, pressure balancing is required by means of openings and holes in the adjacent parts.
- Bearings rotating at low speeds ( $n \cdot d_M < 50\,000 \text{ min}^{-1} \cdot \text{mm}$ ) and their housings must be filled completely with grease. The churning friction occurring in this case is negligible. It is important that the grease introduced is held in the bearing or vicinity of the bearing by the seals and baffle plates. The reservoir effect of grease in the vicinity of the bearing leads to an increase in the lubrication interval. However, this is conditional on direct contact with the grease in the bearing (grease bridge). Occasional shaking will also lead to fresh grease moving into the bearing from its environment (internal relubrication).

## Rolling bearing greases Arcanol

- If a high temperature is expected in the bearing, the appropriate grease should be supplemented by a grease reservoir that has a surface as large as possible facing the bearing and that dispenses oil. The favourable quantity for the reservoir is two to three times the normal degree of filling. The reservoir must be provided either on one side of the bearing or preferably to an identical extent on both sides.
- In the case of higher speed parameters, the bearing temperature may settle at a higher value, in some cases over several hours, if the grease quantity during the starting phase has not been set correctly, *Figure 1*. The temperature is higher and the increased temperature is longer, the more the bearings and the cavities adjacent to the bearings are filled with grease and the more difficult it is for grease to escape freely. A remedy is a so-called interval running-in process with appropriately determined stand-still periods for cooling. If suitable greases and grease quantities are used, equilibrium is achieved after a very short time.

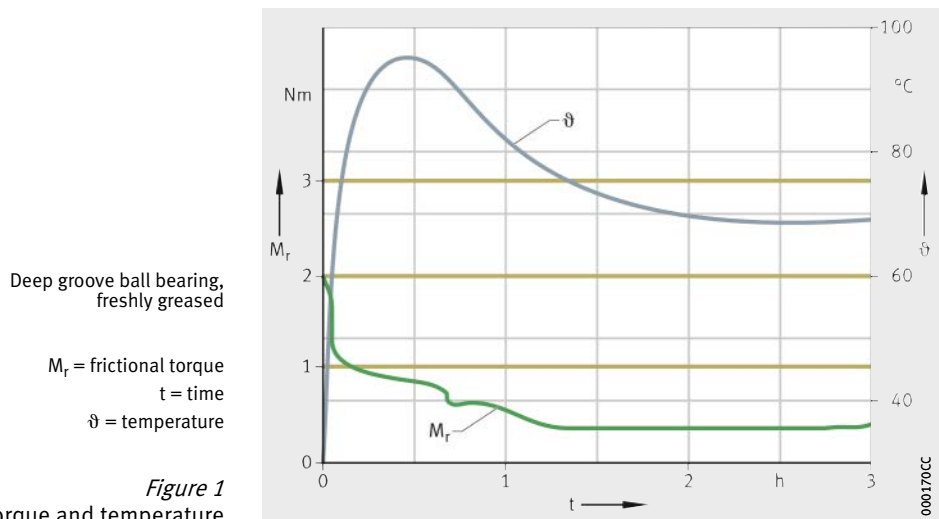

### Grease operating life

The grease operating life describes the period over which the grease is capable, without relubrication, of lubricating the bearing to an adequate extent. Once the grease operating life has been reached, function of the bearing is only conditionally possible and the bearing will fail relatively quickly as a result of lubricant failure. The grease operating life is therefore a decisive value if it is shorter than the calculated bearing life. It applies where rolling bearings cannot be relubricated.

The factors influencing the grease operating life are:

- grease quantity and distribution
- type of grease (thickener, base oil, additives)
- production process of the grease
- bearing type and size
- magnitude and type of load
- speed parameter
- bearing temperature
- mounting conditions.

### Calculation of the grease operating life

A guide value for the grease operating life  $t_{fG}$  can be determined in approximate terms using the following equation:

$$t_{fG} = t_f \cdot K_T \cdot K_P \cdot K_R \cdot K_U \cdot K_S$$

$t_f$	h
Basic grease operating life	
$K_T$	–
Correction factor for increased temperature	
$K_P$	–
Correction factor for increased load	
$K_R$	–
Correction factor for oscillation	
$K_U$	–
Correction factor for environmental influences	
$K_S$	–
Correction factor for vertical shaft.	

## Rolling bearing greases Arcanol



The values determined are guide values only, since the determination is based on statistical principles. It is assumed that operating conditions are constant and that a suitable lubricant is present in a sufficient quantity. This is rarely the case in practice. As a result, the calculation model cannot supply precise values and almost no account is taken of other influences such as thermal conduction or contaminants.

Guidelines on calculating the grease operating life:

- In the case of combined rolling bearings, the radial bearing and axial bearing must be calculated separately. The shorter grease operating life is then taken as the defining value.
- If the outer ring rotates, there may be a reduction in the grease operating life.
- In the case of yoke and stud type track rollers, angular defects must not occur. In this case, the effects of the rotating outer ring are already taken into consideration in the bearing type factor  $k_f$ .



The grease operating life cannot be determined using the method described in the following cases:

- The grease can flow out of the rolling bearing
  - There is excessive vapourisation of the base oil
  - The bearing is not sealed
  - The axial bearing has a horizontal axis of rotation
- Air is sucked through the rolling bearing during operation
  - There is a risk of increased grease oxidation
- Combined rotary and linear motion is present
  - The grease is distributed over the whole stroke length
- Contamination, water or other fluids enter the bearings
- There is no type factor for the bearings.

If the grease operating life is longer than three years, the lubricant manufacturer should be consulted.

### Basic grease operating life

The basic grease operating life  $t_f$  is dependent on the bearing-specific speed parameter  $k_f \cdot n \cdot d_M$ . It is determined from *Figure 2* and the table, page 20.

The basic grease operating life in accordance with *Figure 2* is valid in the following cases:

- greases with a proven performance capability for bearings
- bearing arrangements with a bearing temperature lower than the upper continuous limit temperature of the grease  $T_{upperlimit}$
- a load ratio of  $C_0/P \geq 20$
- constant speed and load
- load in the main direction (radial in radial bearings, axial in axial bearings)
- radial bearings with a horizontal axis of rotation
- a rotating inner ring
- bearing arrangements without disruptive environmental influences.

$t_f$  = basic grease operating life  
 $k_f \cdot n \cdot d_M$  = bearing-specific speed parameter

*Figure 2*  
 Basic grease operating life  $t_f$

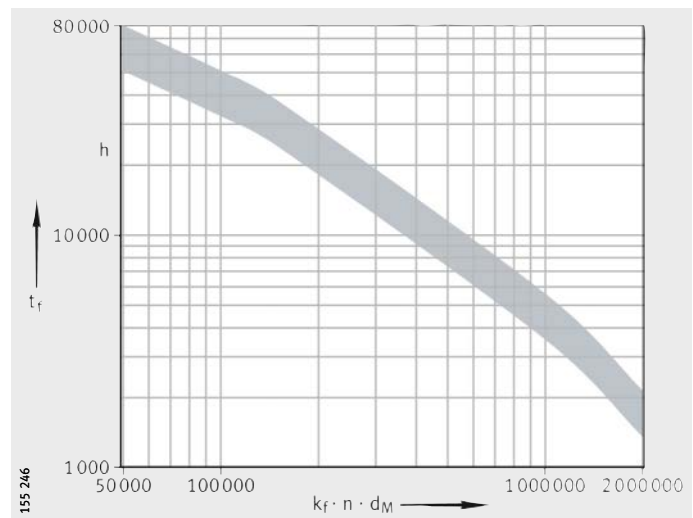

$k_f$  – Bearing type factor, see table, page 20  
 $n$  – Operating speed or equivalent speed  
 $d_M$  – mm Mean bearing diameter  $(d + D)/2$ .

# Rolling bearing greases Arcanol

Factor  $k_f$ ,  
as a function of bearing type

Bearing type	Factor $k_f$
Axial needle roller bearings, axial cylindrical roller bearings	58
Axial deep groove ball bearings	5,5
Axial angular contact ball bearings double row	2
Tapered roller bearings	4
Crossed roller bearings	4,4
Ball bearing track rollers single row	1
double row	2
Drawn cup needle roller bearings	4,2
Needle roller and cage assemblies, needle roller bearings	3,6
Self-aligning ball bearings	1,45
Spherical roller bearings without central rib	8
with central rib	8
Deep groove ball bearings single row, Generation C	0,8
single row	1
double row	1,5
Angular contact ball bearings single row	1,6
single row, X-life	1,3
double row	2
double row, X-life	1,6
Radial insert ball bearings, housing units	1
Spindle bearings $\alpha = 15^\circ$	0,75
$\alpha = 25^\circ$	0,9
Yoke type track rollers, stud type track rollers with cage, full complement cylindrical roller set	20
full complement needle roller set	40
Yoke type track rollers PWTR, stud type track rollers PWKR	6
Four point contact bearings –	1,6
X-life	1,3
Cylindrical roller bearings single row	2
double row (not valid for NN30)	3
full complement cylindrical roller set	6
Cylindrical roller bearings LSL, ZSL	3

Correction factor  
for increased temperature

An increase in temperature leads to an acceleration in the speed of reaction and thus of oxidation or ageing.

As a rule of thumb, the following applies: an increase in temperature of 15 K will reduce the grease operating life by half. In the case of high grade greases, however, this effect is only pronounced above the so-called upper continuous limit temperature  $T_{upperlimit}$ . If the bearing temperature is above  $T_{upperlimit}$ , the reduction in the grease operating life due to temperature must be determined, *Figure 3*.



This diagram must not be used if the bearing temperature is higher than the upper operating temperature of the grease used, see page 6. If necessary, another grease must be selected.

$K_T$  = temperature factor

① K above  $T_{upperlimit}$

*Figure 3*  
Temperature factor

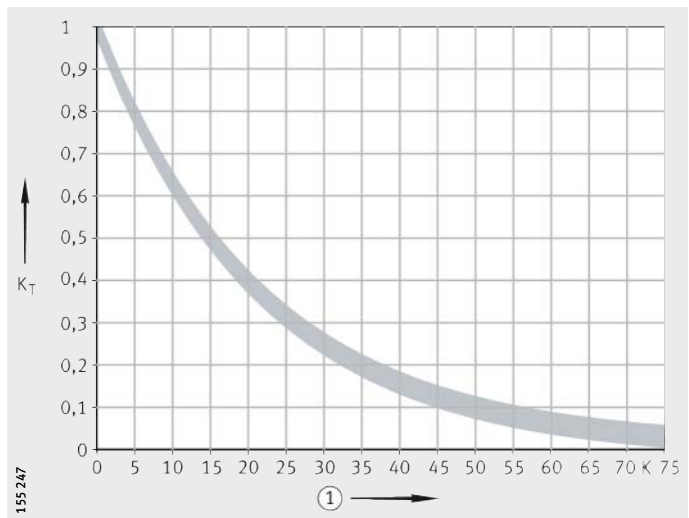

# Rolling bearing greases Arcanol

Correction factor for increased load

Under higher bearing load, greases are subjected to greater strain. As a function of the load ratio  $C_0/P$  and bearing type, this influence can be taken into consideration using the factor  $K_p$ , *Figure 4*.

$K_p$  = load factor  
 $C_0/P$  = ratio between basic static load rating and equivalent dynamic bearing load

①, ②, ③, ④, see table

*Figure 4*  
Load factor

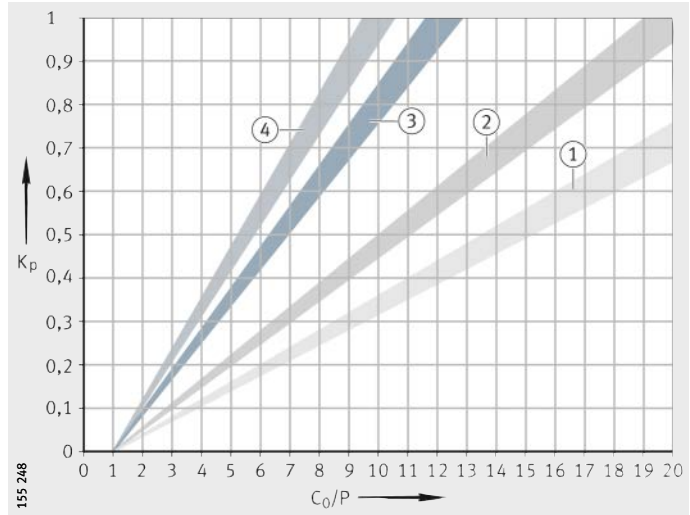

Load factor  $K_p$

Curve <sup>1)</sup>	Bearing type
①	Axial angular contact ball bearings, double row
	Axial deep groove ball bearings
	Axial needle roller bearings, axial cylindrical roller bearings
	Crossed roller bearings
②	Needle roller and cage assemblies, needle roller bearings
	Drawn cup needle roller bearings with open ends, drawn cup needle roller bearings with closed end
	Spherical roller bearings with central rib
	Yoke and stud type track rollers, with cage or full complement cylindrical roller set
	Yoke and stud type track rollers with full complement needle roller set
	Yoke type track rollers PWTR, stud type track rollers PWKR
	Cylindrical roller bearings, double row (not valid for NN30)
③	Tapered roller bearings
	Spherical roller bearings without central rib (E1)
	Barrel roller bearings
	Four point contact bearings
	Cylindrical roller bearings, single row (constant, alternating, without axial load)
	Cylindrical roller bearings LSL, ZSL
	Cylindrical roller bearings, full complement
④	Ball bearing type track rollers (single row, double row)
	Self-aligning ball bearings
	Deep groove ball bearings (single row, double row)
	Angular contact ball bearings (single row, double row)
	Radial insert ball bearings, housing units

<sup>1)</sup> Curves, *Figure 4*.



Oscillation factor Oscillating movements place a higher strain on the grease than continuously rotating bearings. The strain is placed continuously on the same grease volume, since no new grease can be drawn into the lubrication contact. As a result, the grease at the contact becomes depleted. In order to reduce fretting corrosion, the lubrication interval should be shortened. The reduction-inducing influence can be taken into consideration using the oscillation factor  $K_R$ , *Figure 6*. This is active starting from a swivel angle  $\varphi < 180^\circ$ , *Figure 5* and *Figure 6*.

$\varphi$  = swivel angle

*Figure 5*  
Swivel angle

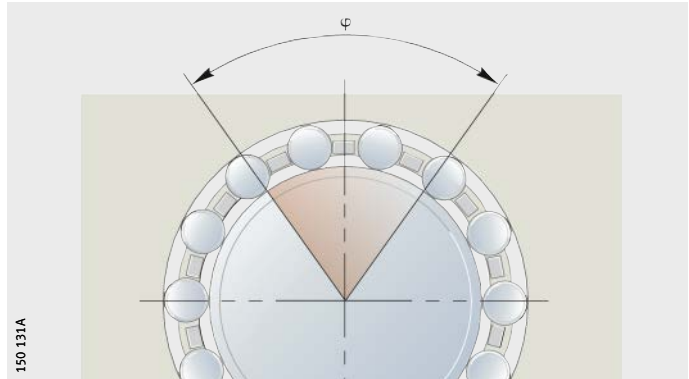

$K_R$  = oscillation factor  
 $\varphi$  = swivel angle

*Figure 6*  
Oscillation factor

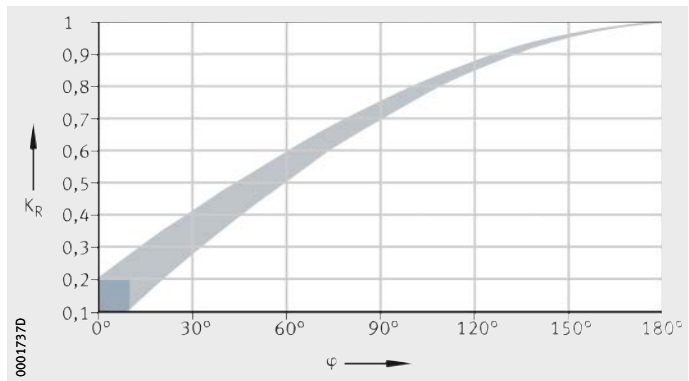

# Rolling bearing greases Arcanol

**Environment factor** The factor  $K_U$  takes account of slight influences as a result of moisture, shaking forces, slight vibration and shocks, see table.

 It does not take account of strong environmental influences such as water, aggressive media, contamination, nuclear radiation and extreme vibrations such as those occurring in vibratory machines.

In relation to contamination, the influence of contamination on rating life calculation must also be observed.

Environmental influence	Environment factor $K_U$
Slight (for example, test rig)	1
Moderate (standard)	0,8
Heavy (for example, outdoor application)	0,5

**Factor for vertical shaft** If increased escape of grease is expected, for example in the case of radial bearings with a vertical axis of rotation, this influence must be taken into consideration using the factor  $K_S$ , see table.

Vertical shaft	Factor $K_S$
Vertical shaft (depending on sealing)	0,5 to 0,7
Otherwise	1

**Relubrication interval** Where rolling bearings are suitable for relubrication, regular relubrication is recommended in order to ensure the reliable function of the bearings.

Experience shows that, as a guide value, the relubrication interval  $t_{fR}$  for most applications can be calculated as follows:

$$t_{fR} = 0,5 \cdot t_{fG}$$

$t_{fR}$  h  
Guide value for relubrication interval

$t_{fG}$  h  
Guide value for grease operating life, see page 17.

After this time, the grease in the bearing is used up to the extent that addition or replacement is necessary. Once the grease operating life is reached, the grease is in such a condition that it can no longer be simply pressed out of the bearing. For organisational and economic reasons, the lubrication intervals should be matched to the maintenance periods that are required in operational terms.

Experience shows that relubrication intervals longer than one year should not be recommended, since they are frequently forgotten.

Relubrication should also be carried out before and after extended periods without operation, in order to achieve anti-corrosion protection in the bearing and to facilitate restarting with fresh grease.

The relubrication procedure should be carried out while the bearing is warm from operation and slowly rotating, in order to ensure good grease distribution. Old grease must be allowed to leave the bearing unhindered.

### **Relubrication and relubrication intervals**

Relubrication or a grease change is necessary if the grease operating life is shorter than the expected bearing life.

Relubrication can be carried out in various ways. Relubrication can often still be carried out using lever grease guns and lubrication nipples. Increasing importance is being attached to greasing systems such as the automatic lubricator of the CONCEPT series as well as central lubrication systems and grease spraying equipment. It is important that the used grease can be displaced by the new grease so that grease is replaced but overlubrication does not occur.

# Rolling bearing greases Arcanol

## Examples of grease lubrication

There are various possibilities for supplying a rolling bearing with grease. The method used is based on the requirements of the specific bearing arrangement.

### Sealed bearings

Rolling bearings that are sealed and filled with grease at the time of manufacture facilitate simple adjacent constructions, *Figure 7*. Sealing shields or sealing washers are provided, depending on the application, as single seals or in addition to a further outer seal. Contact type sealing washers increase the bearing temperature as a result of seal friction. Sealing washers and non-contact seals form a gap relative to the inner ring and do not therefore influence friction. Deep groove ball bearings sealed on both sides are filled with a lithium soap grease of consistency grade 2 or 3, where the softer grease is used for small bearings.

The grease quantity introduced fills approx. 90% of the undisturbed free bearing volume, *Figure 7*. It is determined such that, under normal operating and environmental conditions, a long operating life will be achieved. The grease is distributed during a short running-in phase and settles to a large extent in the undisturbed part of the free bearing cavity, in other words on the inner sides of the washers. No significant co-rotation is found after this time and the bearing runs with low friction. Once the running-in phase is complete, the friction is only 30% to 50% of the starting friction.

- ① Design with sealing shields
- ② Design with non-contact sealing washers
- ③ Design with contact type sealing washers

*Figure 7*  
Sealed bearings

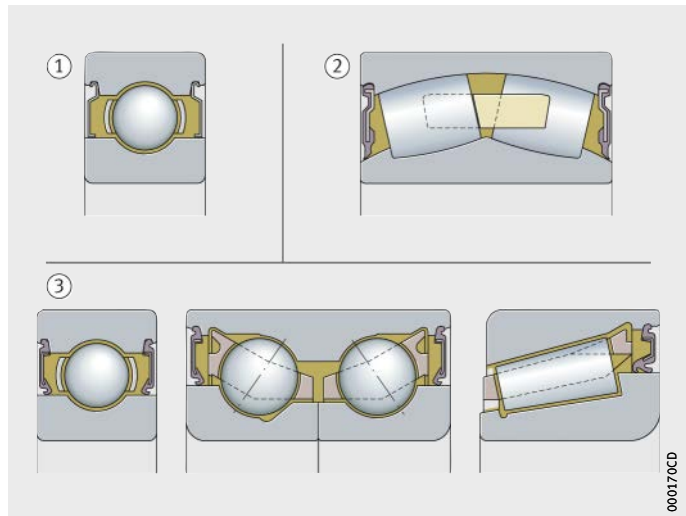

Bearings sealed on one side with baffle plate

The deep groove ball bearing is sealed on one side, while a baffle plate with a grease reservoir is arranged on the other side, *Figure 8*. The bearing thus has a larger grease quantity in the vicinity of the bearing but not in the bearing itself. At high temperature, the grease reservoir releases oil intensively and over the long term to the deep groove ball bearing. As a result, long running times are achieved without the occurrence of additional lubricant friction. Suitable greases can be recommended by agreement by the Schaeffler engineering service.

- ① Baffle plate
- ② Grease reservoir

*Figure 8*

Bearing sealed on one side with baffle plate

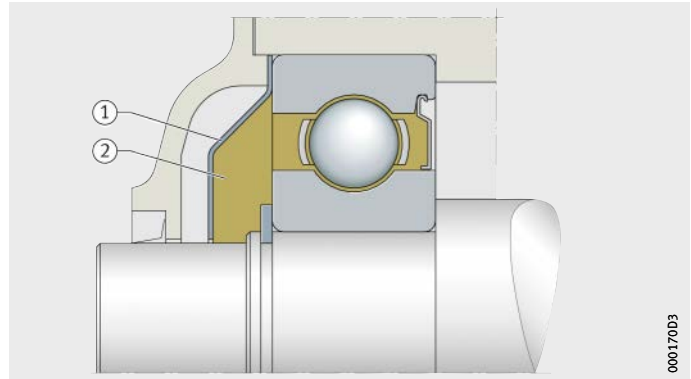

Vertically arranged bearings with baffle plate

Where bearings have a pumping action or bearing arrangements have a vertical shaft, a baffle plate prevents the grease from flowing out of the bearing at all or not as quickly, *Figure 9*. In the case of bearing types that have higher proportions of sliding motion and a pronounced pumping effect in particular (for example tapered roller bearings), an outer baffle plate is advantageous if not always sufficient at higher circumferential speeds.

Short relubrication intervals are a further measure for ensuring supply of grease.

- ① Incorrect
- ② Correct
- ③ Baffle plate

*Figure 9*

Bearing with vertical arrangement and baffle plate

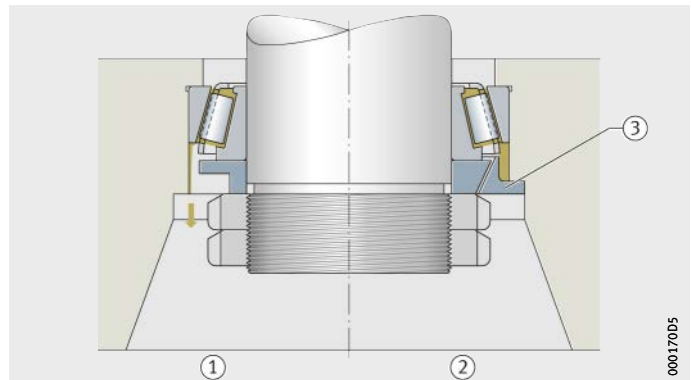

# Rolling bearing greases Arcanol

Lubrication hole in the outer ring

The grease is pressed into the bearing interior via a lubrication groove and lubrication holes in the bearing outer ring, *Figure 10*. Due to the direct and symmetrical feed of the grease, a uniform supply to both rows of rollers is achieved. On both sides, sufficiently large cavities for collection of the used grease or openings for the escape of grease must be provided.

- ① Lubrication groove with lubrication holes
- ② Cavity for grease collection

*Figure 10*  
Relubrication via the lubrication groove in the outer ring

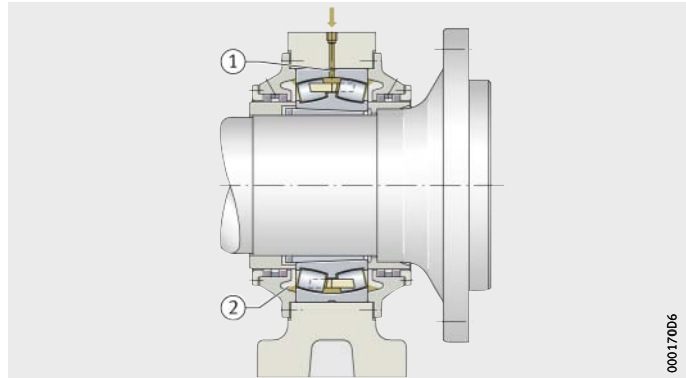

Spherical roller bearings

The spherical roller bearing is relubricated from one side, *Figure 11*. During relubrication, grease is intended to exit on the opposing side. Grease back-up may occur if large quantities are used frequently for relubrication and there is resistance to the escape of grease. This can be remedied by a grease outlet hole or a grease valve.

During the startup phase, the movement of grease leads to a temperature increase (approx. 20 K to 30 K above the equilibrium temperature), which may last for one or more hours. The type and consistency of grease have a strong effect on the temperature behaviour.

- ① Lubrication groove
- ② Grease outlet hole

*Figure 11*  
Relubrication of a spherical roller bearing

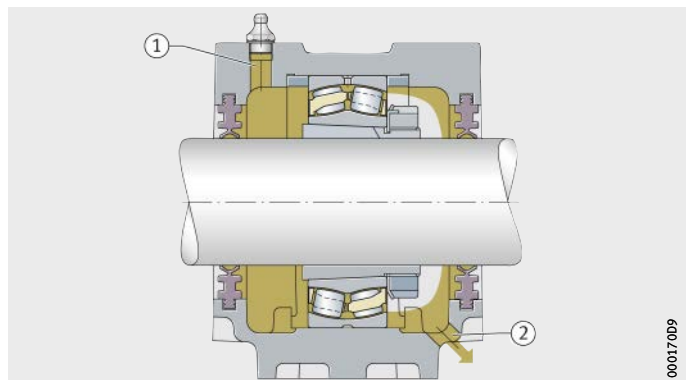

## Grease quantity regulator

A grease quantity regulator conveys excess grease to the exterior through a narrow gap between the housing and a regulating washer rotating with the shaft, *Figure 12*. Where long relubrication intervals, higher circumferential speeds and an easily movable grease are present, there is a risk that only a small quantity of grease will remain in the bearing on the side with the regulating washer. This can be remedied by moving the gap between the rotating regulating washer and the stationary outer part towards the shaft.

In a normal grease quantity regulator with a gap on the outside, there is a strong pumping action. A moderate pumping action is achieved if the gap is arranged approximately on the pitch circle diameter of the bearing. If the gap is on the inside, practically no pumping action is achieved, the washer acts as a baffle plate and retains the grease in the bearing.

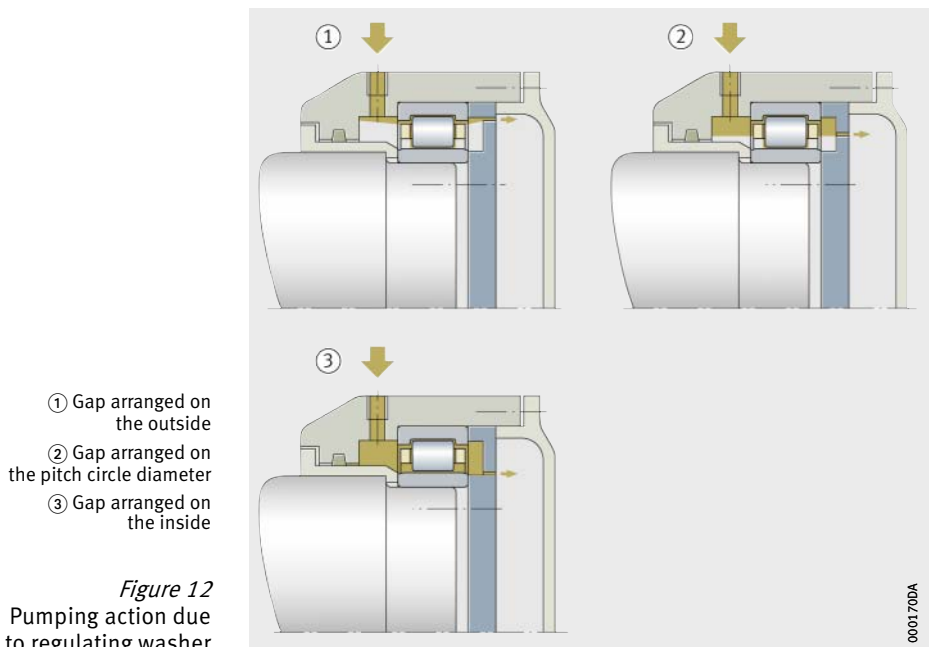

# Rolling bearing greases Arcanol

## Targeted relubrication from the side

A washer with holes allows targeted lubrication from one side, *Figure 13*. During relubrication, the grease passes through the hole in the washer directly into the gap between the cage and outer ring. The grease displaced during relubrication collects in the free space, which must be emptied from time to time via an opening. The chamber on the right side of the bearing is filled with grease at the time of mounting. This is intended to improve sealing. During relubrication while stationary, good replacement of used grease by fresh grease is achieved if the holes are arranged around the circumference of the washer such that the grease is distributed uniformly around the circumference of the bearing. The holes located in the area of the filling hole must therefore be further from each other than the diametrically positioned holes. This gives uniform flow resistance and the relubrication grease pushes the used grease uniformly out of the bearing. The replacement of used grease by fresh grease is promoted by large relubrication quantities.

- ① Filling hole
- ② Washer
- ③ Hole
- ④ Chamber
- ⑤ Opening
- ⑥ Free space

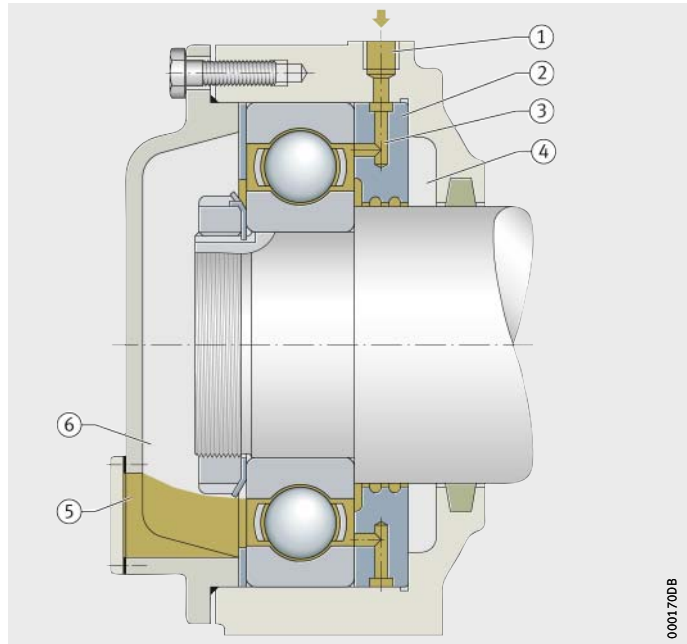

000170DB

*Figure 13*  
Targeted relubrication from the side



## Bearing pairs

The pair of angular contact ball bearings is supplied with fresh grease via lubrication holes. These are located in the washer, which is arranged between the bearings, *Figure 14*. This prevents grease back-up caused by grease being fed to the small diameter. The centrifugal force directs it outwards to the larger diameter. This effect only occurs in bearings with an asymmetrical cross-section and thus in angular contact ball bearings and tapered roller bearings. If a bearing pair with a symmetrical cross-section is lubricated from the centre, a regulating washer or exit opening should be arranged next to each individual bearing. It is important that the escape resistance at each point is approximately the same. If this is not the case, the grease will tend to move towards the side with the lowest escape resistance. There is then a risk of lubricant undersupply on the opposing side.

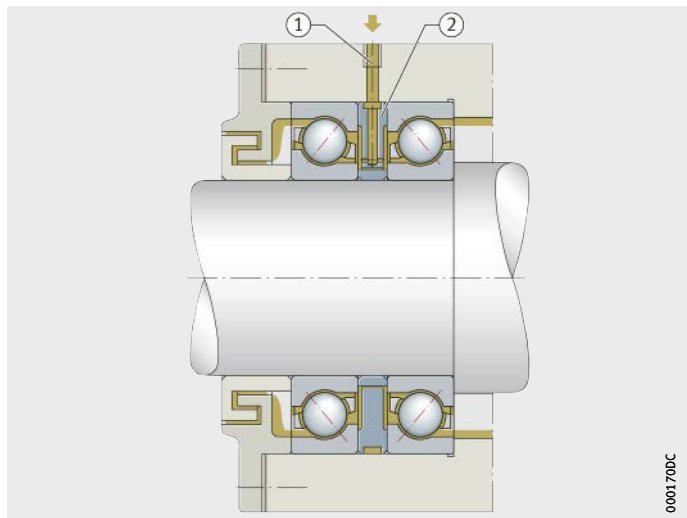

- ① Lubrication hole
- ② Washer

*Figure 14*  
Lubrication of a bearing pair  
from the centre

## Summary

The examples show that correct guidance of grease is normally costly. It is preferable that these costs are expended in the case of expensive machines or difficult operating conditions such as higher speed, load or temperature. In these cases, the replacement of used grease must be ensured and overlubrication must be prevented.

In a normal application, such costs are not necessary. This is shown by operationally reliable bearings with a lateral grease buffer. These grease buffers on both sides of the bearing gradually release oil for lubrication of the contact surfaces and offer additional protection against contamination of the bearing interior. In general, it is also the case that relubrication of bearings represents a source of defects. For example, contamination can enter the bearing from outside through relubrication. Lifetime lubrication should always be used in preference to relubrication.

# Rolling bearing greases Arcanol

## Storage of lubricants

Arcanol lubricants can be stored for up to 36 months from their fill date.

For storage, the following conditions must be fulfilled:

- closed room
- temperature between 0 °C and +40 °C
- relative humidity less than 65%
- storage in closed original containers.

It is only under these preconditions that the greases can be used in the bearings without loss in performance until the end of the three-year period.

## Disposal

In order to prevent environmental contamination, disposal of the lubricant must be carried out in accordance with the regulations in the relevant country of use.

All materials used (plastics, metals) must be fed separately to recycling facilities.

Grease-soaked materials must be disposed of by environmentally acceptable methods.

The depleted lubricant containers contain residues of lubricant and must be disposed of together with waste materials soaked with grease.

## Further information

- TPI 176, Lubrication of Rolling Bearings.



# Rolling bearing greases Arcanol

**Universal greases** Multipurpose greases are greases with a wide range of applications.

**Arcanol MULTITOP**

The rolling bearing grease Arcanol MULTITOP is a multipurpose grease for demanding applications with a wide temperature range. The special base oil mixture comprising a mineral oil and a synthetic oil contributes, together with the EP additives, to a high performance capability. At low temperatures ( $-50\text{ }^{\circ}\text{C}$ ), it has a low starting moment, gives rapid and reliable oil release and is suitable for applications involving vibrations and shock loads. It is also suitable for bearings with higher speeds and for a continuous limit temperature of  $+85\text{ }^{\circ}\text{C}$ .

Typical areas of application are:

- motor vehicles
- rolling mills
- construction machinery
- spinning and grinding spindles.

The criteria for application are:

- universal application
- moderate to high loads
- low startup temperatures
- possible over a wide temperature range
- possible over a very wide speed range
- good relubrication.



*Figure 15*  
Areas of application

## Applications

Bearing type	Speed limit $n \cdot d_m$ mm/min
Ball bearings	800 000
Cylindrical roller bearings	
Other roller bearings <sup>1)</sup>	350 000

<sup>1)</sup> Not for axial cylindrical roller bearings and axial spherical roller bearings.

## Technical data

Designation	Value	Unit	
Thickener type	Lithium soap	–	
Base oil type	Partially synthetic oil	–	
Base oil viscosity at	+40 °C	82	mm <sup>2</sup> /s
	+100 °C	12,5	mm <sup>2</sup> /s
Continuous limit temperature	+80	°C	
Operating temperature range	–50 to +140	°C	
Density	0,87	kg/dm <sup>3</sup>	
NLGI grade	2	–	

## Available containers

Container	SAP no.	Designation
250 g tube	019143990-0000-10	ARCANOL-MULTITOP-250G#K
400 g cartridge	019144016-0000-11	ARCANOL-MULTITOP-400G#K
1 kg can	038652161-0000-12	ARCANOL-MULTITOP-1KG#K
5 kg bucket	038652170-0000-10	ARCANOL-MULTITOP-5KG#K
12,5 kg bucket	069455490-0000-10	ARCANOL-MULTITOP-12,5KG#S
25 kg hobbock	019144008-0000-10	ARCANOL-MULTITOP-25KG#K
50 kg hobbock	–	–
180 kg drum	019143974-0000-10	ARCANOL-MULTITOP-180KG#K

## Rolling bearing greases Arcanol

### Arcanol MULTI2

Arcanol MULTI2 is a multipurpose grease for ball bearings up to 62 mm outside diameter. It is a special grease for low-noise bearing arrangements, is highly suitable for low temperatures and is suitable for rolling bearings with high loads and an increased speed range.

The criteria for application are:

- moderate to high loads
- low startup temperatures
- possible over a wide temperature range
- possible over a wide speed range
- good relubrication.



*Figure 16*  
Areas of application

## Applications

Bearing type	Speed limit $n \cdot d_m$ mm/min
Ball bearings	500 000
Cylindrical roller bearings	
Other roller bearings <sup>1)</sup>	250 000

<sup>1)</sup> Not for axial cylindrical roller bearings and axial spherical roller bearings.

## Technical data

Designation	Value	Unit
Thickener type	Lithium soap	–
Base oil type	Mineral oil	–
Base oil viscosity at	+40 °C	110
	+100 °C	11
		mm <sup>2</sup> /s
		mm <sup>2</sup> /s
Continuous limit temperature	+75	°C
Operating temperature range	–30 to +120	°C
Density	0,95	kg/dm <sup>3</sup>
NLGI grade	2	–

## Available containers

Container	SAP no.	Designation
250 g tube	019003471-0000-11	ARCANOL-MULTI2-250G#K
400 g cartridge	019143893-0000-11	ARCANOL-MULTI2-400G#K
1 kg can	038652129-0000-10	ARCANOL-MULTI2-1KG#K
5 kg bucket	019143907-0000-10	ARCANOL-MULTI2-5KG#K
12,5 kg bucket	069455570-0000-10	ARCANOL-MULTI2-12,5KG#S
25 kg hobbock	019143885-0000-10	ARCANOL-MULTI2-25KG#K
50 kg hobbock	–	–
180 kg drum	019143850-0000-10	ARCANOL-MULTI2-180KG#K

## Rolling bearing greases Arcanol

### Arcanol MULTI3

Arcanol MULTI3 is a multipurpose grease for ball bearings larger than 62 mm outside diameter. It is suitable for bearings with high loads, an increased speed range and for bearing arrangements with a vertical shaft. It is used in large electric motors and generators, agricultural and construction machinery, ventilators and truck wheelset bearings.

The criteria for application are:

- moderate to high loads
- low startup temperatures
- possible over a wide temperature range.



*Figure 17*  
Areas of application



## Applications

Bearing type	Speed limit $n \cdot d_m$ mm/min
Ball bearings	500 000
Cylindrical roller bearings	
Other roller bearings <sup>1)</sup>	250 000

<sup>1)</sup> Not for axial cylindrical roller bearings and axial spherical roller bearings.

## Technical data

Designation	Value	Unit
Thickener type	Lithium soap	–
Base oil type	Mineral oil	–
Base oil viscosity at	+40 °C	80
	+100 °C	10
		mm <sup>2</sup> /s
Continuous limit temperature	+75	°C
Operating temperature range	–30 to +120	°C
Density	0,95	kg/dm <sup>3</sup>
NLGI grade	3	–

## Available containers

Container	SAP no.	Designation
250 g tube	019143940-0000-10	ARCANOL-MULTI3-250G#K
400 g cartridge	016727355-0000-11	ARCANOL-MULTI3-400G#K
1 kg can	038684187-0000-11	ARCANOL-MULTI3-1KG#S
5 kg bucket	038652137-0000-11	ARCANOL-MULTI3-5KG#K
12,5 kg bucket	069455643-0000-10	ARCANOL-MULTI3-12,5KG#S
25 kg hobbock	038652153-0000-10	ARCANOL-MULTI3-25KG#K
50 kg hobbock	–	–
180 kg drum	019143915-0000-10	ARCANOL-MULTI3-180KG#K

# Rolling bearing greases Arcanol

## Heavy duty greases

Heavy duty greases are greases that are suitable for particularly high demands on load carrying capacity.

### Arcanol LOAD150

Arcanol LOAD150 is a heavy duty grease for all applications with line contact. It is the standard grease for linear guidance systems in machine tools and is particularly suitable for short stroke motions. It is used as a wheelset bearing grease for tapered roller bearings in commercial vehicles, agricultural machinery and construction machinery at higher temperatures as well as for cylindrical roller bearings in large electric motors and generators. Special high pressure additives ensure very good load carrying capacity.

The criteria for application are:

- higher temperatures
- particularly suitable for line contact.

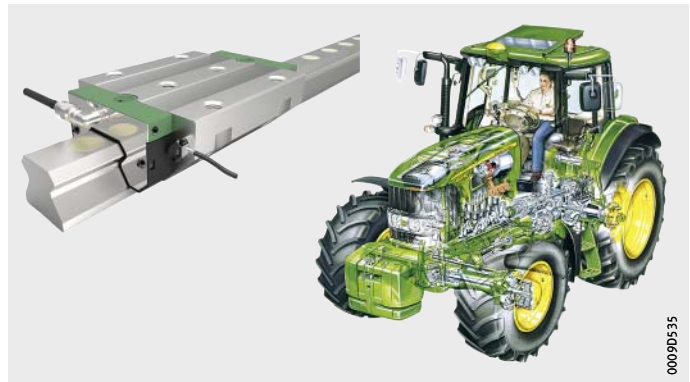

*Figure 18*  
Areas of application

## Applications

Bearing type	Speed limit $n \cdot d_m$ mm/min
Ball bearings	500 000
Cylindrical roller bearings	
Other roller bearings <sup>1)</sup>	200 000

<sup>1)</sup> Not for axial cylindrical roller bearings and axial spherical roller bearings.

## Technical data

Designation	Value	Unit	
Thickener type	Lithium complex soap	–	
Base oil type	Mineral oil	–	
Base oil viscosity at	+40 °C	160	mm <sup>2</sup> /s
	+100 °C	15,5	mm <sup>2</sup> /s
Continuous limit temperature	+95	°C	
Operating temperature range	–20 to +140	°C	
Density	0,9	kg/dm <sup>3</sup>	
NLGI grade	2	–	

## Available containers

Container	SAP no.	Designation
250 g tube	–	–
400 g cartridge	055358152-0000-10	ARCANOL-LOAD150-400G#S
1 kg can	055359159-0000-10	ARCANOL-LOAD150-1KG#S
5 kg bucket	–	–
12,5 kg bucket	069455686-0000-10	ARCANOL-LOAD150-12,5KG#S
25 kg hobbock	–	–
50 kg hobbock	059810025-0000-10	ARCANOL-LOAD150-50KG#S
180 kg drum	–	–

# Rolling bearing greases Arcanol

## Arcanol LOAD220

Arcanol LOAD220 is a heavy duty grease for rolling mill plant, paper machinery and rail vehicles. It gives very good performance at high loads and low speeds and, due to its highly effective EP additives, offers security of the bearing arrangement under shock loads and good support to the bearing sealing arrangement, good water resistance and high anti-corrosion protection.

The criteria for application are:

- universal application
- moderate to high loads
- possible over a wide temperature range.



*Figure 19*  
Areas of application

## Applications

Bearing type	Speed limit $n \cdot d_m$ mm/min
Ball bearings	500 000
Cylindrical roller bearings	
Other roller bearings <sup>1)</sup>	300 000

<sup>1)</sup> Not for axial cylindrical roller bearings and axial spherical roller bearings.

## Technical data

Designation	Value	Unit
Thickener type	Lithium/calcium soap	–
Base oil type	Mineral oil	–
Base oil viscosity at	+40 °C	245
	+100 °C	20
		mm <sup>2</sup> /s
Continuous limit temperature	+80	°C
Operating temperature range	–20 to +140	°C
Density	0,9	kg/dm <sup>3</sup>
NLGI grade	2	–

## Available containers

Container	SAP no.	Designation
250 g tube	–	–
400 g cartridge	064741028-0000-10	ARCANOL-LOAD220-400G#S
1 kg can	038652099-0000-10	ARCANOL-LOAD220-1KG#K
5 kg bucket	–	–
12,5 kg bucket	069455724-0000-10	ARCANOL-LOAD220-12,5KG#S
25 kg hobbock	019143761-0000-10	ARCANOL-LOAD220-25KG#K
50 kg hobbock	–	–
180 kg drum	019143745-0000-10	ARCANOL-LOAD220-180KG#K

## Rolling bearing greases Arcanol

### Arcanol LOAD400

Arcanol LOAD400 is a heavy duty grease for main bearings in wind turbines, mining machinery and construction machinery. It is suitable for high loads together with vibrations and shock loads, offers very good protection against false brinelling, low startup friction at low temperatures and is suitable for vertical shafts.

The criteria for application are:

- universal application
- moderate to high loads
- high dynamic additional loading
- low startup temperatures
- low startup friction over a wide speed range
- also suitable for bearing arrangements with a vertical shaft position.



*Figure 20*  
Areas of application

## Applications

Bearing type	Speed limit $n \cdot d_m$ mm/min
Ball bearings	400 000
Cylindrical roller bearings	
Other roller bearings <sup>1)</sup>	200 000

<sup>1)</sup> Not for axial cylindrical roller bearings and axial spherical roller bearings.

## Technical data

Designation	Value	Unit
Thickener type	Lithium/calcium soap	–
Base oil type	Mineral oil	–
Base oil viscosity at	+40 °C	400
	+100 °C	27
		mm <sup>2</sup> /s
Continuous limit temperature	+80	°C
Operating temperature range	–40 to +130	°C
Density	0,9	kg/dm <sup>3</sup>
NLGI grade	2	–

## Available containers

Container	SAP no.	Designation
250 g tube	–	–
400 g cartridge	019143818-0000-11	ARCANOL-LOAD400-400G#K
1 kg can	038652102-0000-10	ARCANOL-LOAD400-1KG#K
5 kg bucket	019143834-0000-10	ARCANOL-LOAD400-5KG#K
12,5 kg bucket	069455740-0000-10	ARCANOL-LOAD400-12,5KG#S
25 kg hobbock	019143800-0000-10	ARCANOL-LOAD400-25KG#K
50 kg hobbock	019143826-0000-10	ARCANOL-LOAD400-50KG#K
180 kg drum	019143788-0000-10	ARCANOL-LOAD400-180KG#K

## Rolling bearing greases Arcanol

### Arcanol LOAD460

Arcanol LOAD460 is a heavy duty grease for large rolling bearings. It is particularly suitable for main bearings in wind turbines under cold climate conditions and for bearings with pin cages, such as bearings in mining and construction machinery. It offers very good protection against false brinelling, very low startup friction at low temperatures, good water resistance and good anti-corrosion protection.

The criteria for application are:

- larger bearings
- high loads
- low startup temperatures
- possible over a wide temperature range
- vibrations during standstill
- vibrations in operation.



*Figure 21*  
Areas of application



## Applications

Bearing type	Speed limit $n \cdot d_m$ mm/min
Ball bearings	400 000
Cylindrical roller bearings	
Other roller bearings <sup>1)</sup>	200 000

<sup>1)</sup> Not for axial cylindrical roller bearings and axial spherical roller bearings.

## Technical data

Designation	Value	Unit
Thickener type	Lithium/calcium soap	–
Base oil type	Mineral oil	–
Base oil viscosity at	+40 °C	400
	+100 °C	25,8
		mm <sup>2</sup> /s
		mm <sup>2</sup> /s
Continuous limit temperature	+80	°C
Operating temperature range	–40 to +130	°C
Density	0,93	kg/dm <sup>3</sup>
NLGI grade	1	–

## Available containers

Container	SAP no.	Designation
250 g tube	–	–
400 g cartridge	065825144-0000-10	ARCANOL-LOAD460-400G#S
1 kg can	065825390-0000-10	ARCANOL-LOAD460-1KG#S
5 kg bucket	065826825-0000-10	ARCANOL-LOAD460-5KG#S
12,5 kg bucket	069455864-0000-10	ARCANOL-LOAD460-12,5KG#S
25 kg hobbock	065827066-0000-10	ARCANOL-LOAD460-25KG#S
50 kg hobbock	065827120-0000-10	ARCANOL-LOAD460-50KG#S
180 kg drum	065827180-0000-10	ARCANOL-LOAD460-180KG#S

# Rolling bearing greases Arcanol

## Arcanol LOAD1000

Arcanol LOAD1000 is a heavy duty grease for large rolling bearings with very high loads, low speeds and strong vibrations in mining machinery, construction machinery and in the cement industry. It has a high base oil viscosity in order to protect the rolling bearing under mixed friction conditions, offers good support to the bearing sealing arrangement, good water resistance and good anti-corrosion protection.

The criteria for application are:

- very high loads
- shocks
- possible over a wide temperature range
- low to moderate speeds.



*Figure 22*  
Areas of application

## Applications

Bearing type	Speed limit $n \cdot d_m$ mm/min
Ball bearings	300 000
Cylindrical roller bearings	
Other roller bearings <sup>1)</sup>	200 000

<sup>1)</sup> Not for axial cylindrical roller bearings and axial spherical roller bearings.

## Technical data

Designation	Value	Unit	
Thickener type	Lithium/calcium soap	–	
Base oil type	Mineral oil	–	
Base oil viscosity at	+40 °C	1000	mm <sup>2</sup> /s
	+100 °C	38	mm <sup>2</sup> /s
Continuous limit temperature	+80	°C	
Operating temperature range	–20 to +130	°C	
Density	0,93	kg/dm <sup>3</sup>	
NLGI grade	2	–	

## Available containers

Container	SAP no.	Designation
250 g tube	–	–
400 g cartridge	–	–
1 kg can	–	–
5 kg bucket	019003463-0000-10	ARCANOL-LOAD1000-5KG#K
12,5 kg bucket	–	–
25 kg hobbock	019143729-0000-10	ARCANOL-LOAD1000-25KG#K
50 kg hobbock	066624860-0000-10	ARCANOL-LOAD1000-50KG#S
180 kg drum	019143710-0000-10	ARCANOL-LOAD1000-180KG#K

# Rolling bearing greases Arcanol

## High temperature greases

High temperature greases are greases that must withstand high application temperatures.

### Arcanol TEMP90

Arcanol TEMP90 is a high temperature grease for applications with a continuous limit temperature of up to +90 °C. It is suitable for rolling bearings in couplings, electric motors, traction motors, generators and motor vehicles. It has very good low temperature characteristics as well as very high stability in applications with a vertical shaft at high temperatures.

The criteria for application are:

- universal application
- moderate to high loads
- low external temperatures
- possible over a wide temperature range.

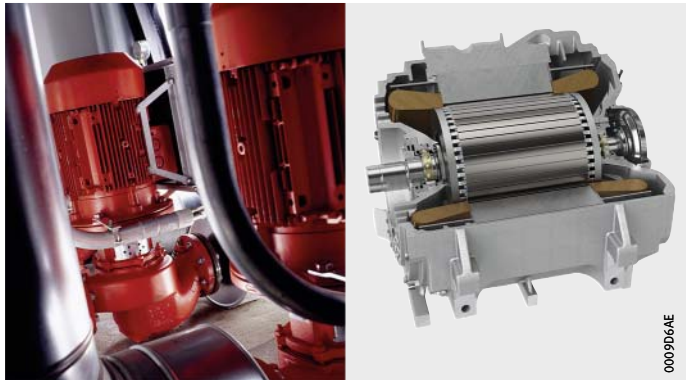

*Figure 23*  
Areas of application

## Applications

Bearing type	Speed limit $n \cdot d_m$ mm/min
Ball bearings	700 000
Cylindrical roller bearings	
Other roller bearings <sup>1)</sup>	250 000

<sup>1)</sup> Not for axial cylindrical roller bearings and axial spherical roller bearings.

## Technical data

Designation	Value	Unit	
Thickener type	Polycarbamide	–	
Base oil type	Mineral oil	–	
Base oil viscosity at	+40 °C	148	mm <sup>2</sup> /s
	+100 °C	15,5	mm <sup>2</sup> /s
Continuous limit temperature	+90	°C	
Operating temperature range	–40 to +160	°C	
Density	0,9	kg/dm <sup>3</sup>	
NLGI grade	3	–	

## Available containers

Container	SAP no.	Designation
250 g tube	–	–
400 g cartridge	019144172-0000-10	ARCANOL-TEMP90-400G#K
1 kg can	038652188-0000-10	ARCANOL-TEMP90-1KG#K
5 kg bucket	038652196-0000-10	ARCANOL-TEMP90-5KG#K
12,5 kg bucket	–	–
25 kg hobbock	019144164-0000-10	ARCANOL-TEMP90-25KG#K
50 kg hobbock	–	–
180 kg drum	019144148-0000-10	ARCANOL-TEMP90-180KG#K

## Rolling bearing greases Arcanol

### Arcanol TEMP110

Arcanol TEMP110 is a high temperature grease for applications with a continuous limit temperature of up to +110 °C. It is suitable for rolling bearings under high thermal and mechanical load in electric motors, traction motors, generators and motor vehicles.

It has very good startup characteristics at low temperatures and long relubrication intervals due to the use of a partially synthetic base oil.

The criteria for application are:

- universal application
- moderate to high loads
- low startup temperatures
- possible over a wide temperature range
- possible over a wide speed range.

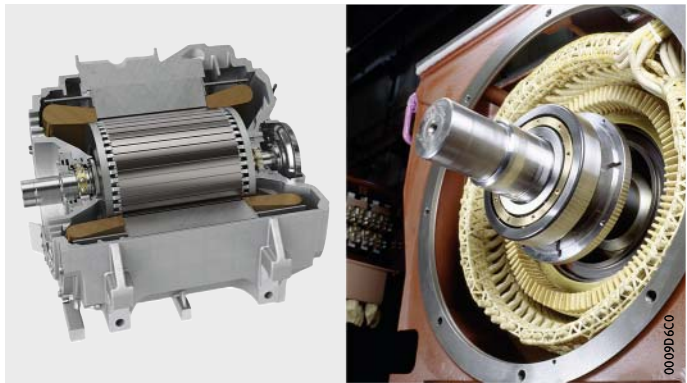

*Figure 24*  
Areas of application

## Applications

Bearing type	Speed limit $n \cdot d_m$ mm/min
Ball bearings	500 000
Cylindrical roller bearings	
Other roller bearings <sup>1)</sup>	250 000

<sup>1)</sup> Not for axial cylindrical roller bearings and axial spherical roller bearings.

## Technical data

Designation	Value	Unit	
Thickener type	Lithium complex soap	–	
Base oil type	Partially synthetic oil	–	
Base oil viscosity at	+40 °C	130	mm <sup>2</sup> /s
	+100 °C	14	mm <sup>2</sup> /s
Continuous limit temperature	+110	°C	
Operating temperature range	–35 to +160	°C	
Density	0,9	kg/dm <sup>3</sup>	
NLGI grade	2	–	

## Available containers

Container	SAP no.	Designation
250 g tube	–	–
400 g cartridge	019144075-0000-10	ARCANOL-TEMP110-400G#K
1 kg can	019144067-0000-10	ARCANOL-TEMP110-1KG#K
5 kg bucket	–	–
12,5 kg bucket	–	–
25 kg hobbock	–	–
50 kg hobbock	038705478-0000-10	ARCANOL-TEMP110-50KG#K
180 kg drum	–	–

## Rolling bearing greases Arcanol

### Arcanol TEMP120

Arcanol TEMP120 is a high temperature grease for applications with a continuous limit temperature of up to +120 °C. It is suitable for high temperature applications under high loads in continuous casting plant in the steel industry and for rolling bearings with grease lubrication in the dry sections of paper machinery. It has very high water resistance and offers very good anti-corrosion protection.

The criteria for application are:

- universal application
- moderate to high loads
- low startup temperatures
- possible over a wide temperature range
- high temperatures.

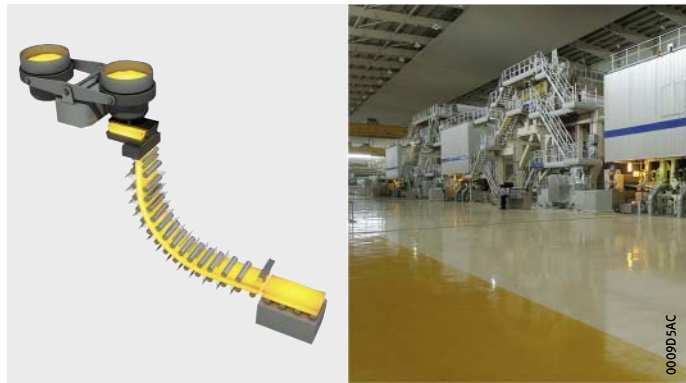

*Figure 25*  
Areas of application



## Applications

Bearing type	Speed limit $n \cdot d_m$ mm/min
Ball bearings	300 000
Cylindrical roller bearings	
Other roller bearings <sup>1)</sup>	150 000

<sup>1)</sup> Not for axial cylindrical roller bearings and axial spherical roller bearings.

## Technical data

Designation	Value	Unit	
Thickener type	Polycarbamide	–	
Base oil type	Synthetic oil	–	
Base oil viscosity at	+40 °C	400	mm <sup>2</sup> /s
	+100 °C	40	mm <sup>2</sup> /s
Continuous limit temperature	+120	°C	
Operating temperature range	–30 to +180	°C	
Density	0,93	kg/dm <sup>3</sup>	
NLGI grade	2	–	

## Available containers

Container	SAP no.	Designation
250 g tube	–	–
400 g cartridge	089855167-0000-10	ARCANOL-TEMP120-400G#S10
1 kg can	038652200-0000-10	ARCANOL-TEMP120-1KG#K
5 kg bucket	019144113-0000-10	ARCANOL-TEMP120-5KG#K
12,5 kg bucket	–	–
25 kg hobbock	019144105-0000-10	ARCANOL-TEMP120-25KG#K
50 kg hobbock	–	–
180 kg drum	–	–

# Rolling bearing greases Arcanol

## Arcanol TEMP200

Arcanol TEMP200 is a high temperature grease for applications with a continuous limit temperature of up to +200 °C. It is suitable for rolling bearings in track rollers in baking machinery, kiln trucks, piston pins in compressors as well as in chemical plant with very high demands on thermal and chemical resistance.

The criteria for application are:

- high temperatures
- chemically aggressive environments.



*Figure 26*  
Areas of application

## Applications

Bearing type	Speed limit $n \cdot d_m$ mm/min
Ball bearings	300 000
Cylindrical roller bearings	
Other roller bearings <sup>1)</sup>	200 000

<sup>1)</sup> Not for axial cylindrical roller bearings and axial spherical roller bearings.

## Technical data

Designation	Value	Unit	
Thickener type	PTFE	–	
Base oil type	Alkoxyfluoro oil	–	
Base oil viscosity at	+40 °C	550	mm <sup>2</sup> /s
	+100 °C	49	mm <sup>2</sup> /s
Continuous limit temperature	+200	°C	
Operating temperature range	–30 to +260	°C	
Density	1,9	kg/dm <sup>3</sup>	
NLGI grade	2	–	

## Available containers

Container	SAP no.	Designation
70 g tube	038652218-0000-10	ARCANOL-TEMP200-70G#K
400 g cartridge	–	–
1 kg can	019144121-0000-10	ARCANOL-TEMP200-1KG#K
5 kg bucket	–	–
12,5 kg bucket	–	–
25 kg hobbock	–	–
50 kg hobbock	–	–
180 kg drum	–	–

# Rolling bearing greases Arcanol

**Special greases** Special greases are sought for particular areas of applications.

**Arcanol SPEED2,6** Arcanol SPEED2,6 is a rolling bearing grease for high speed applications with speeds and low loads. It is suitable for bearing arrangements in machine tools, in particular for spindle bearings, as well as in rotary table bearings and instrument bearings. It has good localised resistance even in applications with a vertical shaft.

Typical areas of application are:

- machine tools
- instruments.

The criteria for application are:

- low temperatures
- high speeds
- particularly suitable for spindle bearings.



*Figure 27*  
Areas of application

## Applications

Bearing type	Speed limit $n \cdot d_m$ mm/min
Ball bearings	2 000 000
Cylindrical roller bearings	
Other roller bearings <sup>1)</sup>	200 000

<sup>1)</sup> Not for axial cylindrical roller bearings and axial spherical roller bearings.

## Technical data

Designation	Value	Unit	
Thickener type	Lithium complex soap	–	
Base oil type	Synthetic oil	–	
Base oil viscosity at	+40 °C	25	mm <sup>2</sup> /s
	+100 °C	6	mm <sup>2</sup> /s
Continuous limit temperature	+80	°C	
Operating temperature range	–40 to +120	°C	
Density	0,94	kg/dm <sup>3</sup>	
NLGI grade	2/3	–	

## Available containers

Container	SAP no.	Designation
250 g tube	019144040-0000-10	ARCANOL-SPEED2,6-250G#K
400 g cartridge	062447610-0000-10	ARCANOL-SPEED2,6-400G#S
1 kg can	019144032-0000-10	ARCANOL-SPEED2,6-1KG#K
5 kg bucket	–	–
12,5 kg bucket	–	–
25 kg hobbock	019144059-0000-10	ARCANOL-SPEED2,6-25KG#K
50 kg hobbock	–	–
180 kg drum	–	–

## Rolling bearing greases Arcanol

**Arcanol V1B3** Arcanol V1B3 is a rolling bearing grease for applications with strong vibrations or oscillating movements. It is suitable for rotor blade adjustment systems in wind turbines, construction machinery, crusher plant in quarries and the cement industry, rope sheaves with a rotating outer ring, packaging machinery, rail vehicles and applications with a vertical shaft.

The criteria for application are:

- oscillating operation, especially with small swivel angles or vibrations
- moderate to high loads
- low startup temperatures
- low startup friction
- vertical shaft and rotating outer ring.

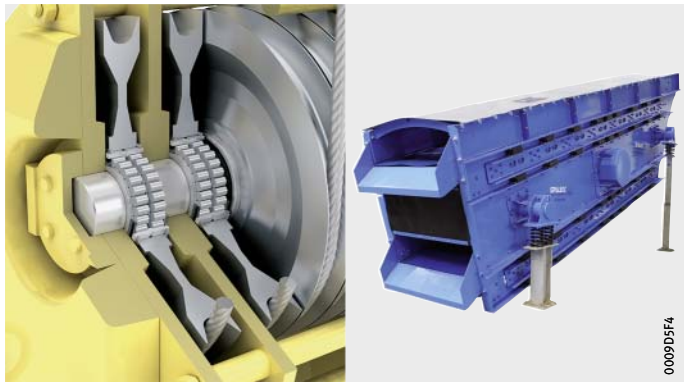

*Figure 28*  
Areas of application

## Applications

Bearing type	Speed limit $n \cdot d_m$ mm/min
Ball bearings	350 000
Cylindrical roller bearings	
Other roller bearings <sup>1)</sup>	200 000

<sup>1)</sup> Not for axial cylindrical roller bearings and axial spherical roller bearings.

## Technical data

Designation	Value	Unit
Thickener type	Lithium complex soap	–
Base oil type	Mineral oil	–
Base oil viscosity at	+40 °C	170
	+100 °C	14
		mm <sup>2</sup> /s
		mm <sup>2</sup> /s
Continuous limit temperature	+90	°C
Operating temperature range	–30 to +150	°C
Density	0,9	kg/dm <sup>3</sup>
NLGI grade	3	–

## Available containers

Container	SAP no.	Designation
250 g tube	–	–
400 g cartridge	055289568-0000-10	ARCANOL-VIB3-400G#S
1 kg can	038652226-0000-10	ARCANOL-VIB3-1KG#K
5 kg bucket	019144210-0000-10	ARCANOL-VIB3-5KG#K
12,5 kg bucket	–	–
25 kg hobbock	019144202-0000-10	ARCANOL-VIB3-25KG#K
50 kg hobbock	055289746-0000-10	ARCANOL-VIB3-50KG#S
180 kg drum	–	–

# Rolling bearing greases Arcanol

**Arcanol Food2** Arcanol FOOD2 is a rolling bearing grease for rolling bearing arrangements in the food industry. It is certified for kosher and halal in accordance with NSF-H1 registration (registration no. 150727), has very good water resistance, offers very good anti-corrosion protection and very good resistance to chemical cleaning agents.

Typical areas of application are:

- applications with food contact
- H1 to USDA
- bearing positions with an NSF-H1 requirement (food contact).

The criteria for application are:

- universal application
- good relubrication.



*Figure 29*  
Areas of application



## Applications

Bearing type	Speed limit $n \cdot d_m$ mm/min
Ball bearings	400 000
Cylindrical roller bearings	
Other roller bearings <sup>1)</sup>	200 000

<sup>1)</sup> Not for axial cylindrical roller bearings and axial spherical roller bearings.

## Technical data

Designation	Value	Unit	
Thickener type	Aluminium complex soap	–	
Base oil type	Synthetic oil	–	
Base oil viscosity at	+40 °C	150	mm <sup>2</sup> /s
	+100 °C	18	mm <sup>2</sup> /s
Continuous limit temperature	+70	°C	
Operating temperature range	–30 to +120	°C	
Density	0,9	kg/dm <sup>3</sup>	
NLGI grade	2	–	

## Available containers

Container	SAP no.	Designation
250 g tube	–	–
400 g cartridge	019143648-0000-10	ARCANOL-FOOD2-400G#K
1 kg can	019143621-0000-10	ARCANOL-FOOD2-1KG#K
5 kg bucket	–	–
12,5 kg bucket	070903069-0000-10	ARCANOL-FOOD2-12,5KG#S
25 kg hobbock	019143630-0000-10	ARCANOL-FOOD2-25KG#K
50 kg hobbock	–	–
180 kg drum	–	–

## Rolling bearing greases Arcanol

### Arcanol CLEAN-M

Arcanol CLEAN-M is a special grease for clean room applications in semiconductor manufacture and the production of flat screens. It is suitable for use in linear axes and rolling bearings. It has very low particle emissions and is therefore suitable for machinery in clean rooms and rooms with moderate vacuum conditions.

Typical areas of application are:

- linear systems in chip manufacture
- rolling bearings in the pharmaceutical industry.

The criteria for application are:

- clean room grease
- radiation-resistant grease.



*Figure 30*  
Areas of application

## Applications

Bearing type	Speed limit $n \cdot d_m$ mm/min
Ball bearings	850 000
Cylindrical roller bearings	
Other roller bearings <sup>1)</sup>	–

<sup>1)</sup> Not for axial cylindrical roller bearings and axial spherical roller bearings.

## Technical data

Designation	Value	Unit	
Thickener type	Polycarbamide	–	
Base oil type	Ether oil	–	
Base oil viscosity at	+40 °C	103	mm <sup>2</sup> /s
	+100 °C	12,8	mm <sup>2</sup> /s
Continuous limit temperature	+90	°C	
Operating temperature range	–30 to +180	°C	
Density	0,95	kg/dm <sup>3</sup>	
NLGI grade	2	–	

## Available containers

Container	SAP no.	Designation
250 g tube	069428611-0000-10	ARCANOL-CLEAN-M-250G#S
400 g cartridge	069429111-0000-10	ARCANOL-CLEAN-M-400G#S
1 kg can	069429154-0000-10	ARCANOL-CLEAN-M-1KG#S
5 kg bucket	–	–
12,5 kg bucket	–	–
25 kg hobbock	–	–
50 kg hobbock	–	–
180 kg drum	–	–

## Rolling bearing greases Arcanol

**Arcanol MOTION2** Arcanol MOTION2 is a special grease for rolling bearings and linear systems with oscillating operation, especially for short stroke motions. It is suitable for rotor blade adjustment systems and for linear systems in robots and assembly systems with short stroke lengths, in particular under shock loads and strong vibrations. It offers good protection against fretting corrosion.

Typical areas of application are:

- wind turbines
- linear systems in short stroke applications.

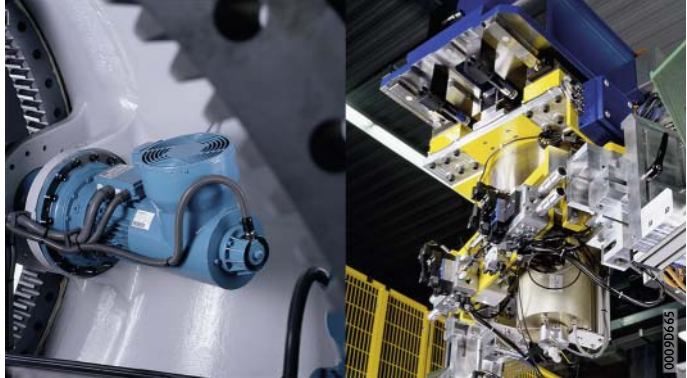

*Figure 31*  
Areas of application

## Applications

Bearing type	Speed limit $n \cdot d_m$ mm/min
Ball bearings	500 000
Cylindrical roller bearings	
Other roller bearings <sup>1)</sup>	–

<sup>1)</sup> Not for axial cylindrical roller bearings and axial spherical roller bearings.

## Technical data

Designation	Value	Unit	
Thickener type	Lithium soap	–	
Base oil type	Synthetic oil	–	
Base oil viscosity at	+40 °C	50	mm <sup>2</sup> /s
	+100 °C	8	mm <sup>2</sup> /s
Continuous limit temperature	+75	°C	
Operating temperature range	–40 to +130	°C	
Density	0,91	kg/dm <sup>3</sup>	
NLGI grade	2	–	

## Available containers

Container	SAP no.	Designation
250 g tube	080265928-0000-10	ARCANOL-MOTION2-250G#S10
400 g cartridge	080266258-0000-10	ARCANOL-MOTION2-400G#S10
1 kg can	080266339-0000-10	ARCANOL-MOTION2-1KG#S
5 kg bucket	080266673-0000-10	ARCANOL-MOTION2-5KG#S
12,5 kg bucket	080266754-0000-10	ARCANOL-MOTION2-12,5KG#S
25 kg hobbock	080267009-0000-10	ARCANOL-MOTION2-25KG#S
50 kg hobbock	080267157-0000-10	ARCANOL-MOTION2-50KG#S
180 kg drum	–	–

# Rolling bearing greases Arcanol

## Arcanol MOUNTINGPASTE

The mounting and multipurpose paste has proven valuable particularly for the mounting of rolling bearings. It facilitates the sliding of bearing rings and prevents stick-slip, scoring, wear and fretting corrosion. It also gives good protection against corrosion. It is pale in colour and does not cause contamination. The mounting paste is applied in a very thin layer so that the metallic sheen turns matt. The permissible operating temperature is between  $-15\text{ }^{\circ}\text{C}$  and  $+150\text{ }^{\circ}\text{C}$ . The paste is resistant to water, water vapour and many alkaline and acidic media.

Typical areas of application are:

- mounting of rolling bearings.



*Figure 32*  
Mounting and multipurpose paste  
MOUNTINGPASTE

### Technical data

Designation	Value	Unit
Thickener type	Calcium complex	–
Base oil type	Mineral oil	–
Base oil viscosity at	+40 °C	46
	+100 °C	–
		mm <sup>2</sup> /s
Continuous limit temperature	–	°C
Operating temperature range	$-15$ to $+150$	°C
Density	1,35	kg/dm <sup>3</sup>
NLGI grade	2/3	–

### Available containers

Container	SAP no.	Designation
70 g tube	038678420-0000-10	ARCANOL-MOUNTINGPASTE-70G#K
250 g tube	019145365-0000-10	ARCANOL-MOUNTINGPASTE-250G#K
400 g cartridge	019145373-0000-10	ARCANOL-MOUNTINGPASTE-400G#K
1 kg can	019145357-0000-10	ARCANOL-MOUNTINGPASTE-1KG#K

### Arcanol ANTICORROSIONOIL

The anti-corrosion oil Arcanol ANTICORROSIONOIL is highly suitable for unpacked rolling bearings. It can also be sprayed on bright metal surfaces of devices, machines and machine elements to give long term anti-corrosion protection when stored indoors. It is not generally necessary to wash anti-corrosion oil out of rolling bearings since it is neutral in behaviour towards all conventional rolling bearing greases and oils.

It can be easily and effectively removed using alkaline solvents and neutral cleaning agents.



*Figure 33*  
Spray can ANTICORROSIONOIL

#### Available container

Container	SAP no.	Designation
0,4 l spray can	019143540-0000-10	ARCANOL-ANTICORROSIONOIL-400G#K

The 0,4 l spray can is filled with the ozone-safe propellant CO<sub>2</sub>.

# Relubrication devices

**Features** Approximately 90% of rolling bearings are lubricated with grease. Lubricators and lubrication systems can be used to automatically provide bearings with the correct quantity of lubricant at the correct intervals. This gives a significant increase in the life of rolling bearings.

Automatic relubrication devices convey fresh lubricant in the defined quantity at the correct time to the contact points of the rolling bearing. The devices adhere to the lubrication and maintenance intervals and prevent undersupply or oversupply of grease. Plant downtime and maintenance costs are reduced as a result.

The relubrication devices are matched to the bearing positions. They have a wide range of applications, for example on electric motors, gearboxes, pumps, compressors and fans, in linear systems, conveying equipment or machine tools.

## **Lubricator FAG CONCEPT2**

This lubricator to protection class IP65 has a very compact design. It has one or two pump bodies that can be individually controlled, depending on the design. This means it can supply one or two lubrication points with lubricant. LC units are available in the size 250 cm<sup>3</sup>. The lubricator is supplied with voltage either from a battery or via a mains power pack. It can work independently or can be optionally controlled by an external control system.

## **Advantages**

The advantages of the lubricator are as follows:

- supply of up to two lubrication points
- supply of set lubricant quantity independent of temperature
- reliable piston pump as delivery pump
- reduced personnel costs compared to manual relubrication
- favourable price/performance ratio
- operating temperature from -20 °C to +70 °C
- facility for setting different lubrication intervals for each lubrication point
- battery or mains operation (DC 24 V) possible
- pressure build-up to 50 bar
- coupling with machine operation possible
- controllable via an external control system.



**Available lubricators  
FAG CONCEPT2**

Designation	Design
CONCEPT2-1P	Battery version with one outlet
CONCEPT2-2P	Battery version with two outlets
CONCEPT2-1P-24VDC	24 V version with one outlet
CONCEPT2-2P-24VDC	24 V version with two outlets

**Available LC units**

Designation	
ARCALUB-C2.LC250-MULTITOP	ARCALUB-C2.LC250-TEMP90
ARCALUB-C2.LC250-MULTI2	ARCALUB-C2.LC250-TEMP110
ARCALUB-C2.LC250-LOAD150	ARCALUB-C2.LC250-TEMP120
ARCALUB-C2.LC250-LOAD220	ARCALUB-C2.LC250-TEMP200
ARCALUB-C2.LC250-LOAD400	ARCALUB-C2.LC250-SPEED2,6
ARCALUB-C2.LC250-LOAD460	ARCALUB-C2.LC250-MOTION2
ARCALUB-C2.LC250-LOAD1000	ARCALUB-C2.LC250-FOOD2
–	ARCALUB-C2.LC250-CLEAN-M

**Further information**

- LC units are also available by agreement with other greases
- Other accessories available by agreement
- Enquiries:  
industrial-services@schaeffler.com, +49 2407 9149-66
- TPI 252, Relubrication Devices.

# Relubrication devices

## Lubrication system FAG CONCEPT8

This single-point and multi-point lubrication system offers high flexibility. It has one, two, three or four pump bodies that can be individually controlled, depending on the design. Each pump body has two outlets and, as a result, up to eight lubrication points can be flexibly provided with the required quantity of lubricant in the correct lubrication interval using just one lubrication system.

The lubrication system FAG CONCEPT8 is designed for a wide variety of operating conditions. Designs for linear systems, the use of oils as lubricant or with an internal heating facility are also available. Lubricant cartridges (LC units) provide the device with lubricant. LC units are available in the size 800 cm<sup>3</sup>.

The lubrication system is supplied with voltage from a mains power pack. Coupling with machine operation is possible. If there is a coupled voltage supply to the machine and lubrication system, the relubrication interval will always be dependent on the number of operating hours.

### Advantages

The advantages of the lubrication system are as follows:

- suitable for oil and grease up to NLGI 3
- supply of up to eight lubrication points
- supply of set lubricant quantity independent of temperature
- reliable piston pump as delivery pump
- reduced personnel costs compared to manual relubrication
- favourable price/performance ratio
- operating temperature from -20 °C to +70 °C
- facility for setting individual lubrication intervals and lubricant quantities
- low operating voltage of DC 24 V
- pressure build-up to 70 bar
- coupling with machine operation possible
- controllable via an external control system.

**Available lubrication systems  
FAG CONCEPT8**

Designation	
CONCEPT8-1P	CONCEPT8-1P-CC
CONCEPT8-2P	CONCEPT8-2P-CC
CONCEPT8-3P	CONCEPT8-3P-CC
CONCEPT8-4P	CONCEPT8-4P-CC
CONCEPT8-1P-LIN	CONCEPT8-1P-OIL
CONCEPT8-2P-LIN	CONCEPT8-2P-OIL
CONCEPT8-3P-LIN	CONCEPT8-3P-OIL
CONCEPT8-4P-LIN	CONCEPT8-4P-OIL

**Available LC units**

Designation	
ARCALUB-C8.LC800-MULTITOP	ARCALUB-C8.LC800-TEMP90
ARCALUB-C8.LC800-MULTI2	ARCALUB-C8.LC800-TEMP110
ARCALUB-C8.LC800-MULTI3	ARCALUB-C8.LC800-TEMP120
ARCALUB-C8.LC800-LOAD150	ARCALUB-C8.LC800-TEMP200
ARCALUB-C8.LC800-LOAD220	ARCALUB-C8.LC800-SPEED2,6
ARCALUB-C8.LC800-LOAD400	ARCALUB-C8.LC800-VIB3
ARCALUB-C8.LC800-LOAD460	ARCALUB-C8.LC800-MOTION2
ARCALUB-C8.LC800-LOAD1000	ARCALUB-C8.LC800-FOOD2
–	ARCALUB-C8.LC800-CLEAN-M

**Further information**

- LC units are also available by agreement with other greases or with oils
- Other accessories available by agreement
- Enquiries:  
industrial-services@schaeffler.com, +49 2407 9149-66
- TPI 252, Relubrication Devices.

# Relubrication devices

## Minimal quantity lubrication device CONCEPT PRECISION GREASE

The minimal quantity lubrication device allows very precise and efficient supply of lubricant to spindle bearings. It is specially designed in terms of the delivery volume per stroke for the greasing of main spindles.

Hoses filled with grease are connected to the outlets. These constitute the lubricant reservoir for relubrication. The cartridge only contains a pressure agent that is pumped into the hoses during delivery. The lubricant and pressure agent are separated from each other by a ball in the hose.

The lubricant is only subjected to pressure during the relubrication process in order to prevent separation of the grease.

### Advantages

The advantages of the minimal quantity lubrication device are as follows:

- optimum relubrication of the main spindles by means of very small quantities
- prevention of impermissible temperature increases
- suitable for bearings with different lubrication requirements
- facility for simple coupling to machine operation
- favourable price/performance ratio.

### Available minimal quantity lubrication device

Designation	Quantity of outlet ducts pieces	Delivery quantity per outlet duct cm <sup>3</sup> /stroke
CONCEPT-PRECISION-GREASE	2	0,0023



# Lubrication lexicon

## A

**Additive** Substance soluble in oil that is added to lubricants in order to improve their characteristics through chemical or physical effects (for example the EP effect, viscosity/temperature behaviour, solidification point, flowability, oxidation resistance, foaming).

**Ageing** Undesirable chemical changes in mineral and synthetic lubricants that occur during use and storage. They are initiated by reaction with oxygen (formation of peroxides, hydrocarbon radicals). This oxidation is accelerated by heat, light and the catalytic influences of metals and other contaminants. Acids and sludge are formed. Anti-ageing products, so-called antioxidants (AO), delay ageing.

**Aluminium complex soap grease** Grease based on aluminium complex soaps with good water resistance and, through the use of high pressure additives, a high pressure capacity. Depending on the base oil, they can be used at up to approx. +160 °C.

**Analysis data** Data that describe the physical and chemical characteristics of lubricants. These include: density, flash point, viscosity, solidification point, dropping point, penetration, acid number and saponification number. Within a certain scope, they allow conclusions to be drawn as to useability.

**Antioxidant (AO)** Agent that leads to a considerable delay in lubricant ageing.

**Anti-wear additive** Additive intended to reduce wear in the mixed friction range. A distinction is made between mildly acting additives (such as aliphatic acids, aliphatic oils), high pressure agents (such as sulphur, phosphorus and zinc compounds) and solid lubricants (such as graphite, PTFE, molybdenum disulphide).

## B

**Base oil** The oil contained in the grease is described as the base oil. The oil proportion varies according to the thickener and intended purpose of the grease. The proportion and viscosity of the base oil change the penetration and friction behaviour of the grease.

**Bleeding** The base oil in the grease becomes separate from the thickener.

## C

**Calcium soap grease** Greases comprising calcium soaps and mineral oils. They have good water resistance and are therefore frequently used as a sealant grease against water. Since they offer hardly any resistance to corrosion, they must contain agents to give anti-corrosion protection. Due to their restricted temperature range of  $-20\text{ }^{\circ}\text{C}$  to  $+50\text{ }^{\circ}\text{C}$ , they are now not widely used.

**Complex grease** Greases based on the metal soaps of high-molecular aliphatic acids. They also contain metal salts derived from low-molecular organic acids. These salts form complexes with the acids that have more favourable characteristics than simple soap greases (temperature limits, behaviour in the presence of water, anti-corrosion protection, pressure absorption capacity).

**Consistency** The consistency of greases changes as a result of mechanical load, see section Penetration, page 80.

## D

**Decompression behaviour** This allows statements on the suitability of greases for use in central lubrication systems (DIN 51816-2).

**Density** Mass per volume of mineral oil products in relation to  $+20\text{ }^{\circ}\text{C}$ . It has the symbol  $\rho$  and is stated in  $\text{g}/\text{cm}^3$ . The density is dependent on the chemical structure of the oil. In oils with the same origin, it increases with increasing viscosity and the increasing degree of refining. Density alone is no measure of quality.

**Dropping point** Guide value for the upper operating temperature of a grease. The grease is heated under standardised test conditions in accordance with DIN ISO 2176. The temperature is determined at which, when a nipple is opened, the sample flows and falls to the base of the test pipe.

**Dynamic viscosity** See section Viscosity, page 82.

# Lubrication lexicon

## E

**Emcor method** Testing of the anti-corrosion characteristics of rolling bearing greases in accordance with DIN 51802.

**EP additive** Oils or greases that contain Extreme Pressure agents in order to prevent wear and fretting.

**Ester** Compound produced by chemical means between acids and alcohols with the release of water. They can be used to produce synthetic oils, whose characteristics are defined by the molecular structure of the ester. Esters of higher alcohols with bivalent aliphatic acids form so-called diester oils. Ester oils comprising multivalent alcohols and various organic acids have particularly high thermal stability.

## F

**Flow pressure** The flow pressure gives information on the consistency of a grease and indicates its flow behaviour. According to DIN 51805, this is the pressure that is required in order to press a stream of grease through a standardised nozzle. According to DIN 51825, it determines the lower operating temperature.

**Four ball test machine (VKA)** Device for testing of lubricants with high pressure and anti-wear agents, standardised in accordance with DIN 51350.  
In order to assess the high pressure additives, four balls are arranged in a pyramid. The upper ball rotates and is subjected to a force until the balls weld together. The welding force measured is the so-called VKA value.  
In order to assess the anti-wear additives, the same test is performed at a defined test force for one hour. The impression diameter of the three static balls is then measured and used as the wear parameter.

## G

**Grease** Consistent mixture of thickener and base oil. A distinction is made between different type of grease. Metal soap greases comprise metal soaps as thickeners and oils. Soap-free greases bind the oil using inorganic gel formers or organic thickeners. Synthetic greases comprise organic or inorganic thickeners and synthetic oils.

**Grease operating life** The period between startup and failure of a bearing as a result of lubricant failure, see page 17. The grease operating life is dependent on the grease quantity, grease type (thickener, base oil, additives), bearing type, bearing size, magnitude and type of load, speed parameters and bearing temperature. It can be estimated if the operating conditions are known.  
The grease operating life is also described as a lubrication interval. It must not be confused with the relubrication interval, see section Relubrication interval, page 80.



<b>H</b>	
<b>High pressure additive</b>	Oils or greases that contain Extreme Pressure agents in order to prevent wear and fretting.
<b>I</b>	
<b>Inhibitor</b>	Agent that delays certain reactions in a lubricant. Inhibitors are used in preference to combat ageing and corrosion processes in lubricants.
<b>K</b>	
<b>Kinematic viscosity</b>	See section Viscosity, page 82.
<b>L</b>	
<b>Lithium soap grease</b>	Greases based on lithium soap. They are characterised by good water resistance and a wide operating temperature range. They contain oxidation and corrosion inhibitors as well as extreme pressure additives (EP). Due to their good characteristics, lithium soap greases are used widely for the lubrication of rolling bearings. The operating limits of normal lithium soap greases are -35 °C and +130 °C.
<b>M</b>	
<b>Mineral oil</b>	Oil derived from crude oil that is processed by distillation and refining for lubrication purposes. In chemical terms, they predominantly comprise hydrocarbons.
<b>Miscibility</b>	Statement as to whether different greases are miscible with each other. This is not always possible with different grades and manufacturers, see section Miscibility of greases and oils, page 12.
<b>N</b>	
<b>NLGI</b>	Abbreviation for the National Lubricating Grease Institute in the USA. Greases are subdivided into grades defined by the NLGI, see section Penetration, page 80.
<b>Nominal viscosity</b>	See section Viscosity, page 82.
<b>O</b>	
<b>Oil separation</b>	The tendency of a grease to release oil in the case of extended storage or at increased temperature. Long term lubrication requires the long term release of a small quantity of oil that must, however, be large enough to ensure supply to all contact surfaces. The oil separation is defined in accordance with DIN 51817.
<b>Operating viscosity</b>	Kinematic viscosity, see section Viscosity, page 82, of an oil at operating temperature. It has the symbol $\nu$ . The operating viscosity can be determined with the aid of a viscosity/temperature diagram. For mineral oils with an average viscosity/temperature behaviour.
<b>Oxidation</b>	See section Ageing, page 76.

# Lubrication lexicon

## P

**Penetration** Indicator of the deformability of a grease.  
It is determined by dropping a standardised brass cone from a defined height into a container filled with grease. The penetration depth after a period of 5 s is then measured. The measurement value is stated in 0,1 mm.  
The National Lubricating Grease Institute has subdivided the measurement values into penetration grades (NLGI grades) 000 to 6. Greases for rolling bearings are normally in the consistency grades 1 to 3. This subdivision is used worldwide and is standardised in accordance with DIN 51818.  
The consistency of greases changes as a result of mechanical load. A distinction is made between static penetration and worked penetration.

**Pressure/viscosity behaviour** The influence of pressure on the viscosity of an oil.  
With increasing pressure, the viscosity of mineral oils increases,

## R

**Reference viscosity** Kinematic viscosity, see section Viscosity, page 82, of an oil, as allocated to a defined lubrication condition. It has the symbol  $\nu_1$ . The reference viscosity can be determined with the aid of the mean bearing diameter and the speed. The so-called viscosity ratio  $\kappa$  of the operating viscosity  $\nu$  to the reference viscosity  $\nu_1$  allows an assessment of the lubrication condition ( $\kappa = \nu/\nu_1$ ).

**Relubrication interval** The period during which a bearing is relubricated. The relubrication interval should be defined as shorter than the grease operating life.

## S

- Seal behaviour** Organic seal materials show behaviour that differs from oils and greases. In some cases, seals undergo swelling, shrinking or embrittlement or even dissolve. The operating temperature and composition of the lubricant as well as the effective duration have a major influence. Information on the resistance of seals is provided by their manufacturers and, as appropriate, by the lubricant manufacturers.
- Solid foreign matter** Insoluble, foreign contaminants in greases. Foreign matter is determined in accordance with DIN 51813.
- Solid lubricant** Substances suspended or directly added in oils and greases that reduce friction. The most well known of these are graphite, PTFE and molybdenum disulphide.
- Static penetration** The penetration measured at +25 °C of a grease sample that was not preworked in the grease shaper, see section Penetration, page 80.
- Stick/slip additive** Agent added to lubricants to prevent jolting sliding motion, for example on the guideways of machine tools.
- Swelling behaviour** The influence, for example on the form and structure of rubber and elastomers, due to the effect of lubricants (DIN 53521).
- Synthetic oil** Synthetic oils are produced by chemical synthesis of molecules. Polymerisation leads to polyalphaolefins (PAO) or polyalkylene glycols (PAG) or condensation reactions lead to esters. Synthetic oils have advantages in comparison with mineral oils at particularly low or particularly high operating temperatures. They are, however, significantly more expensive.

## T

- Thickener** The component of greases that retains the base oil in the grease. The most frequent thickeners are metal soaps (such as Li-, Ca-, Na-, 12-hydroxy stearate) or compounds of the type polycarbamide, PTFE and Mg-Al layered silicate (bentonite).

# Lubrication lexicon

## V

### Viscosity

A fundamental physical characteristic of oils. It indicates the inner friction of a fluid. In a physical sense, it is the resistance opposing the reciprocal displacement of the adjacent layers of a fluid.

A distinction is made between the dynamic viscosity  $\eta$  and the kinematic viscosity  $\nu$ . The kinematic viscosity is the dynamic viscosity relative to the density  $\rho$ . This is subject to the relationship  $\eta = \rho \cdot \nu$ .

The dynamic viscosity is described using the SI units Pa · s and mPa · s. These replace the units Poise P and Centipoise cP that were commonly used previously. Conversion: 1 cP = 10<sup>-3</sup> Pa · s.

The kinematic viscosity described using the SI units m<sup>2</sup>/s and mm<sup>2</sup>/s. These replace the unit Centistoke cSt that was commonly used previously.

The viscosity decreases with increasing temperature and increases with decreasing temperature, see section Viscosity/temperature behaviour (V/T behaviour), page 82. For each viscosity value, the reference temperature must therefore be stated. The nominal viscosity is the kinematic viscosity at +40 °C.

### Viscosity index improver

Additives that are dissolved in the oil and improve the viscosity/temperature behaviour. At high temperatures they induce higher viscosity, while at low temperatures they improve the flow behaviour.

### Viscosity/temperature behaviour (V/T behaviour)

The change in viscosity with temperature. A favourable V/T behaviour is defined as one where the viscosity of an oil does not change considerably with temperature.

## W

### Water resistance

The ability of a grease not to change its characteristics under the influence of water. It is determined by means of a static test in accordance with DIN 51807. It is tested whether and to what extent static, distilled water has an effect on a grease not subjected to load at various temperatures. The result only represents a description of characteristics and does not permit any conclusions as to the water resistance of the grease in practice.

### Water separation capacity

The ability of an oil to separate from water. Testing is carried out in accordance with DIN 51589.

### Worked penetration

The penetration measured at +25 °C of a grease sample that was preworked in the grease shaper (DIN 51804-2 and DIN ISO 2137), see section Penetration, page 80.



## Further information



### Lubrication in general

<https://www.schaeffler.de/content.schaeffler.de/en/products-and-solutions/industrial/product-portfolio/index.jsp?app=portfolio&filtertype=categories&categories=Maintenance%20products%2CLubrication>



### Technical data sheets for FAG ARCANOL

[https://www.schaeffler.de/content.schaeffler.de/en/products-and-solutions/industrial/product-portfolio/maintenance\\_products/lubricants/index.jsp](https://www.schaeffler.de/content.schaeffler.de/en/products-and-solutions/industrial/product-portfolio/maintenance_products/lubricants/index.jsp)



### Material Safety Data Sheets (MSDS) for FAG ARCANOL

<https://www.schaeffler.de/SDS>



### FAG lubrication devices

[https://www.schaeffler.de/content.schaeffler.de/en/products-and-solutions/industrial/product-portfolio/maintenance\\_products/lubrication\\_devices/index.jsp](https://www.schaeffler.de/content.schaeffler.de/en/products-and-solutions/industrial/product-portfolio/maintenance_products/lubrication_devices/index.jsp)

## Schaeffler Technologies AG & Co. KG

Georg-Schäfer-Straße 30  
97421 Schweinfurt  
Germany  
Internet [www.schaeffler.de/en/services](http://www.schaeffler.de/en/services)  
E-mail [industrial-services@schaeffler.com](mailto:industrial-services@schaeffler.com)

In Germany:

Phone 0180 5003872  
Fax 0180 5003873

From other countries:

Phone +49 9721 91-0  
Fax +49 9721 91-3435

Every care has been taken to ensure the correctness of the information contained in this publication but no liability can be accepted for any errors or omissions. We reserve the right to make technical changes.

© Schaeffler Technologies AG & Co. KG  
Issued: 2019, March

This publication or parts thereof may not be reproduced without our permission.

TPI 168 GB-D